

Zebra 4Sight XV6™

Product Reference Guide



ZEBRA

Copyrights, Trademarks, Patents, Limitations of Liability, and Disclaimers

This section lists copyrights, acknowledgments, patent notices, limitations of liability, and disclaimers.

Copyright

© 2020-2025 Zebra Technologies Corp. and/or its affiliates.

3 Overlook Point, Lincolnshire, Illinois 60069, USA

Proprietary Statement

This manual contains proprietary information of Zebra Technologies Corporation and its subsidiaries (“Zebra Technologies”). It is intended solely for the information and use of parties operating and maintaining the equipment described herein. Such proprietary information may not be used, reproduced, or disclosed to any other parties for any other purpose without the express, written permission of Zebra Technologies.

Trademarks

ZEBRA and the stylized Zebra head are trademarks of Zebra Technologies Corp., registered in many jurisdictions worldwide. All other trademarks are the property of their respective owners.

Zebra Software

The object code or source code (collectively, the “Zebra Software”) is the exclusive property of Zebra or its licensors. Zebra Software is protected by copyright and other intellectual property rights. Zebra Software is licensed, not sold. Zebra Software should not be distributed except pursuant to a valid license agreement approved by Zebra containing appropriate restrictions. Use of Zebra Software is governed by the terms of the license agreement that accompanies or is included with the Zebra Software. UNAUTHORIZED COPYING, DISTRIBUTION, MODIFICATION, OR OTHER USE OF ZEBRA SOFTWARE IS STRICTLY PROHIBITED.

Patents

This product may be protected by one or more patents.

Patents: www.zebra.com/patents.

Limitations of Liability

In no event will Zebra or its suppliers be liable for any indirect, special, incidental, economic, cover or consequential damages arising out of the use of or inability to use the product, user documentation or related technical support, including without limitation, damages or costs relating to the loss of profits, business, goodwill, even if advised of the possibility of such damages. In no event will Zebra and its suppliers' liability exceed the amount paid by you, for the product.

Because some jurisdictions do not allow the exclusion or limitation of liability for consequential or incidental damages, the above limitation may not apply to you.

Product Improvements

Continuous improvements of products is a policy of Zebra Technologies. All specifications and designs are subject to change without notice.

Disclaimer

Zebra reserves the right to make changes in specifications at any time and without notice. The information provided by this document is believed to be accurate and reliable. However, neither Zebra nor its suppliers assume any responsibility for its use; or for any infringements of patents or other rights of third parties resulting from its use. No license is granted under any patents or patent right of Zebra.

Publication Date

December 9, 2025

Contents

Chapter 1: Before you begin..... 9

Overview	10
Operating system	12
Inspecting the Zebra 4Sight XV6 package	14
Standard items	14
Additional components	15
General warnings and key to symbols on the unit	16
Zebra 4Sight XV6 safety precautions and key to symbols	16
General warning	17
Handling precautions	17
Manual overview	18
Service Information	19

Chapter 2: Getting started with your Zebra 4Sight XV6 unit ... 21

Steps to get started	22
Operating Zebra 4Sight XV6 for the first time	22
Zebra 4Sight XV6 mounting	24
Connecting peripheral devices	26
Networking connections	28

Chapter 3: Cleaning the air filter and adding devices to Zebra 4Sight XV6 29

Overview	30
Cleaning the air filter	30
Removing the Zebra 4Sight XV6 chassis cover	31
Devices that can be added to your Zebra 4Sight XV6 motherboard	33

Installing full-height, half-length PCIe boards	35
Connecting a device to the SATA3 data connectors	38
Drive assignments	39
Replacing the M.2 SSD attached to the M.2 socket	39
Installing or removing RAM	41
Installing memory	42
Removing memory	42
Adjusting the new memory settings	42

Appendix A: Hardware glossary 43

Glossary	44
--------------------	----

Appendix B: Technical reference 49

Summary	50
Motherboard	50
Memory	52
Default storage drive	52
Fans	52
Air filter	52
Environmental specifications	53
Electrical specifications	54
Warning:	55
Mise en garde:	55
Chassis	56
Coin cell battery/Pile bouton	57
Light emitting diodes (LEDs)	58
Descriptions of external connectors	59
USB 2.0 connectors	60

USB 3.1 connectors	60
Gigabit Ethernet connectors	61
DisplayPort connector.	61
HDMI connector	61
DVI-D video output connector.	61
Analog video output (VGA) connector	63
Serial port connector (COM port)	64
Audio input, audio output, and microphone connectors	65
AC power connector	65
Descriptions of internal connectors	66
SATA3 data connectors for mass storage devices	67
Internal USB 2.0 headers	67
Internal USB 3.1 header	68
Serial port headers.	69
Power supply connectors for peripheral devices (fans)	70

Appendix C: Operating system recovery 71

Zebra 4Sight XV6 Windows 10 IoT Enterprise configuration utility	72
Microsoft Windows Out-Of-Box-Experience (OOBE)	74
Capturing the Zebra 4Sight XV6 operating system partition for deployment	75
OS backup of Zebra 4Sight XV6 Windows 10 IoT Enterprise	77
Making a rescue USB key for Windows 10 IoT Enterprise	79
Restore Windows 10 IoT Enterprise	80

Appendix D: Listing of Zebra 4Sight XV6 imaging computers . . 83

Key feature changes	84
-------------------------------	----

Chapter

1

Before you begin

This chapter introduces you to the key features of Zebra 4Sight XV6.

Overview

The Zebra 4Sight XV6 unit is a self-contained, expandable imaging computer that integrates processing and display capabilities, along with image capture from USB3 Vision and/or GigE Vision cameras. Zebra 4Sight XV6 supports networking and industrial communication (over GigE Ethernet ports or RS-232/RS-485 ports)¹. There are also additional PCIe, M.2, and RAM slots available to add additional boards, storage, and memory, respectively.



Zebra 4Sight XV6 includes a motherboard, Long-DIMM memory modules, an M.2 solid state mass storage device and two fans, all of which are encased within a rugged metal chassis. The XV6I5M32CT model also includes a pre-installed GPU board. You can install Zebra or third-party full-height, half-length PCIe boards in the Zebra 4Sight XV6 unit (such as frame grabbers and I/O boards).

1. Note that the PROFINET protocol is not supported. For support, you can install a Zebra board that supports hardware-assisted PROFINET communication (such as Zebra Indio).

Zebra 4Sight XV6 motherboard

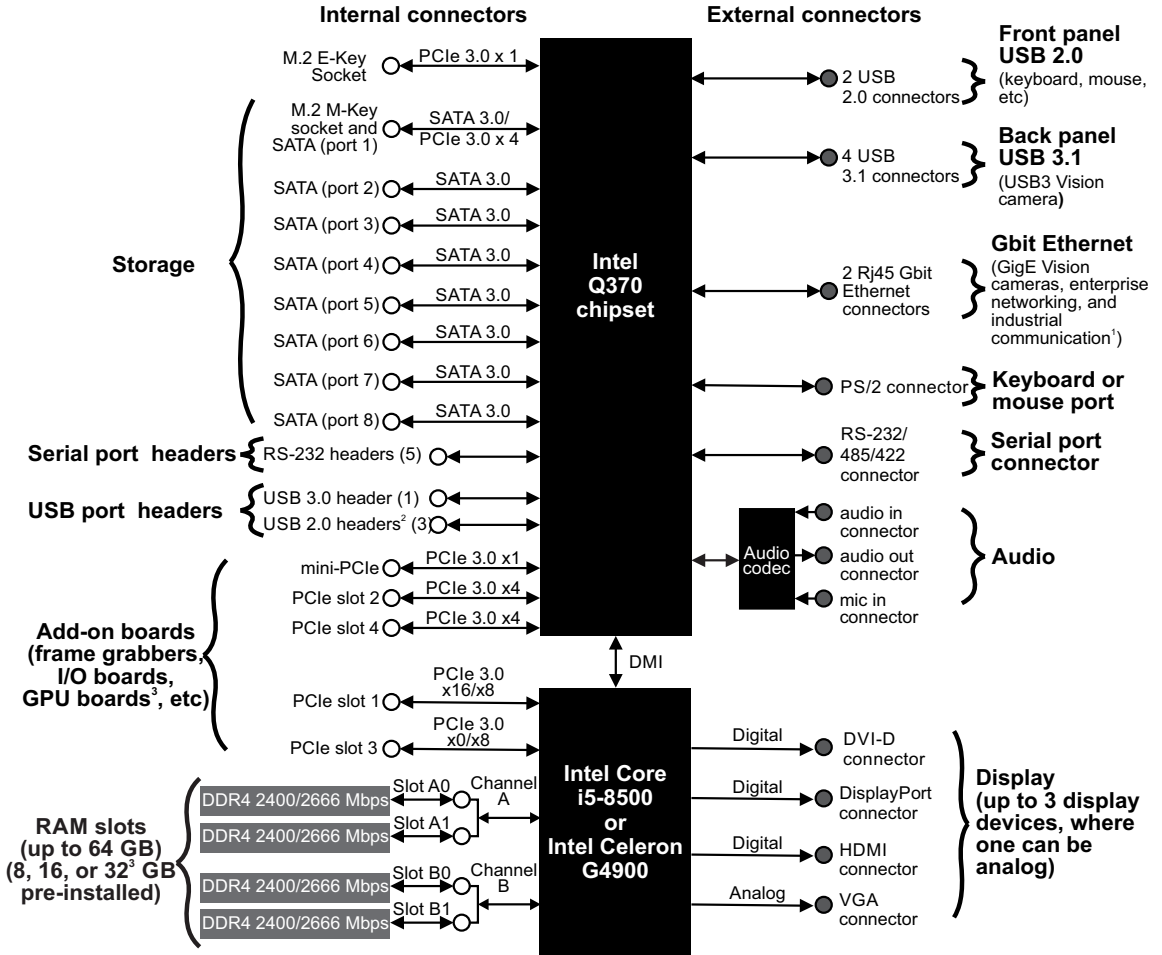

1 Note that the PROFINET protocol and PoE are not supported.

2 Note that the two USB 2.0 connectors on the front panel are already connected to one of the three USB 2.0 headers.

3 Note that the XV6I5M32CT model includes a second SSD, 32 Gbytes of RAM, and a GPU board.

Legend ■ Chips on motherboard ● External connectors on front or back panel of unit ○ Internal connectors on motherboard

Operating system

The Zebra 4Sight XV6 unit comes pre-installed with Microsoft Windows 10 IoT Enterprise 2019 (64-bit version).

- ❖ Note that, when secure boot is enabled, all drivers you install must be properly signed for operating with the secure boot. If your drivers are not properly signed to operate with secure boot, you might have driver issues (for example, driver issues with USB devices). Refer to the documentation accompanying the operating system for more information.

Be aware that each end user is responsible for secure configuration, patch management, and overall security of the system. It is up to the end user to obtain and apply any necessary patches and updates that are made available through the update service offered by the operating system (for example, Windows Update).

Zebra Technologies designed the Zebra 4Sight XV6 unit for a specific use (such as, creating and installing software to process images). You may only use the operating system and associated software on the unit for that use.

You may use other programs with the operating system as long as the other programs:

- Directly support the manufacturer's specific use for the device, or
- Provide system utilities, resource management, or anti-virus or similar protection.

Software that provides consumer or business tasks or processes might not run on the device. This includes email, word processing, spreadsheet, database, scheduling, and personal finance software. The device can use Remote Desktop Services to access such software running on a server.

If you acquired the operating system and associated software on the unit, or on a disc or other media, a genuine Certificate of Authenticity label with a genuine copy of the software identifies licensed software. To be valid, this label must be affixed to the device, or included on or in Zebra's software packaging. If you receive the label separately, it is not valid. You should keep the label on the device or packaging to prove that you are licensed to use the operating system and associated software.

The Microsoft operating system and associated software was designed for systems that do not require fail-safe performance. You may not use the Microsoft operating system and associated software in any device or system in which a malfunction of the software would result in foreseeable risk of injury or death to any person. This includes operation of nuclear facilities, aircraft navigation or communication systems, and air traffic control.

Inspecting the Zebra 4Sight XV6 package

The following tables list standard items that are included in the Zebra 4Sight XV6 package, as well as additional items that are available from Zebra. If anything is missing or damaged, contact Zebra for assistance.

Standard items

Your Zebra 4Sight XV6 package should include the following standard items:

Standard package item	Details
Zebra 4Sight XV6 unit	Encases the following components* : <ul style="list-style-type: none"> • The Zebra 4Sight XV6 motherboard. • An i5-8500 Intel CPU or an Intel Celeron G4900 CPU. • 16 or 8 Gbytes of DDR4 2400/2666 Mbps non-ECC Long-DIMM RAM^{†‡}. • An M.2 connected 120-Gbyte SSD[‡]. • Two cooling fans: one fan for the CPU and one fan for the unit. • 400 W power supply.
Zebra 4Sight XV6 power cable	<ul style="list-style-type: none"> • Standard AC power cable for your region.
Zebra 4Sight XV6 accessory parts	<ul style="list-style-type: none"> • Two SATA3 cables. • Two mounting brackets. • Bag of screws • Four rubber pads for the base of the unit. • Three stick-on anchors for zip ties.
Zebra 4Sight XV6 software package	Includes the following: <ul style="list-style-type: none"> • An operating system license. • Drivers and utilities. These are pre-installed, but if you require their installation files, contact your Zebra representative.
Safety notice with URL to the <i>Zebra 4Sight XV6 installation and hardware reference</i>	A sheet that includes warning symbols and a URL that directs you to the Zebra website to download this manual.

*. Note that the following are the default configurations. Other configurations are also possible, but not specifically discussed in this manual. Contact your Zebra sales representative for more information.

†. If the unit is shipped with 16 Gbytes of memory, it is on two modules.

‡. The XV615M32CT model includes a second 2.5' SSD, 32 Gbytes of DDR4 2666 Mbps non-ECC Long-DIMM RAM, and a GPU board.

Additional components

You can also purchase one or more of the following additional Zebra components:



Additional component	Details
Zebra frame grabbers and Zebra industrial communication and I/O boards.	Contact your Zebra sales representative for availability.
Zebra video cables	Used to connect video sources to Zebra frame grabber boards. Contact your Zebra sales representative for availability.

General warnings and key to symbols on the unit

You should be aware of the meaning of the symbols on the unit and important usage and handling precautions.

Zebra 4Sight XV6 safety precautions and key to symbols

Before installing, connecting to, and using Zebra 4Sight XV6, you shall be aware of the meaning of the symbols on the unit and important safety precautions. The following is a list of precautionary symbols on the unit and their meaning:

Symbol*	Description
	<p>The case of your Zebra 4Sight XV6 can become quite hot and should not be touched while operating. Always allow hot surfaces to cool down before touching your Zebra 4Sight XV6.</p>
	<ul style="list-style-type: none"> • Caution: Consult this manual[†] before installing, connecting to, and using Zebra 4Sight XV6. For hardware installation instructions, refer to <i>Chapter 2: Getting started with your Zebra 4Sight XV6 unit</i> and <i>Chapter 3: Cleaning the air filter and adding devices to Zebra 4Sight XV6</i>; for environmental and electrical specifications and connector pinout descriptions, refer to <i>Appendix B: Technical information</i>. This product must be used as specified; otherwise, the protection provided by its components might be compromised. Any usage, changes, or modifications to Zebra equipment not expressly approved by Zebra could compromise product safety and void the user's authority to operate the equipment. • Refer to the <i>Electrical specifications</i> section, in <i>Appendix B: Technical information</i>, for voltages and current ratings. • To service the equipment, always turn-off the unit and disconnect the main AC power before opening the unit. Always secure the equipment and close the chassis before reconnecting the main AC power. • This product meets the requirements of a Category I installation as per industry standards[‡]. • This product is designed for use in a pollution degree 2 environment as per industry standards[‡]. • This product is designed for indoor use only. • This product is designed to operate at temperatures ranging from 0°C to 45°C at a non-condensing relative humidity of 10 to 90%. • This product is not intended for use at altitudes exceeding 2000 m.

*. Note that these symbols might not necessarily be the same color as depicted.

†. Manual available on the Zebra website at zebra.com/us/en/products/industrial-machine-vision-fixed-scanners.html.

‡. As per CAN/CSA-C22.2 No. 62368-1-14, ANSI/UL 62368-1-2014, EN 62368-1:2014 + A11:2017, IEC 62368-1:2014 (ed. 2.0).

General warning

To avoid damaging the Zebra 4Sight XV6 motherboard in environments where your Zebra 4Sight XV6 is subjected to vibrations, connect your third-party device to your unit using locking cables.

Handling precautions

The Zebra 4Sight XV6 motherboard is sensitive to static electricity and surges. To avoid damaging the motherboard, follow these precautions:

- Be sure to turn off the power to the unit and all peripherals before adding or removing devices.
- Do not touch the heat sinks while the unit is operating; they might be very hot.
- Drain static electricity from your body by touching a metal fixture (or ground) before touching the motherboard.
- Wear a grounded wrist strap designed to prevent static discharge.
- Avoid letting your clothing come in contact with the motherboard.

Manual overview

This installation and hardware reference explains how to setup your Zebra 4Sight XV6 and connect external and internal devices.

This manual contains the following information:

- *Chapter 1: Before you begin* introduces you to the key features of your Zebra 4Sight XV6 unit.
- *Chapter 2: Getting started with your Zebra 4Sight XV6 unit* details how to get your Zebra 4Sight XV6 up and running. It includes instructions for connecting various peripherals to the front and back panels of the Zebra 4Sight XV6 unit.
- *Chapter 3: Cleaning the air filter and adding devices to Zebra 4Sight XV6* details how to change the air filter and how to add devices to the Zebra 4Sight XV6 motherboard.
- The appendices include a technical reference and a glossary.

Service Information

If you have a problem with your equipment, contact Zebra Global Customer Support for your region. Contact information is available at: zebra.com/support. When contacting support, please have the following information available:

- Serial number of the unit
- Model number or product name
- Software/firmware type and version number

Zebra responds to calls by email, telephone, or fax within the time limits set forth in support agreements.

If your problem cannot be solved by Zebra Customer Support, you may need to return your equipment for servicing and will be given specific directions. Zebra is not responsible for any damages incurred during shipment if the approved shipping container is not used. Shipping the units improperly can possibly void the warranty.

If you purchased your Zebra business product from a Zebra business partner, contact that business partner for support.

Chapter

2

Getting started with your Zebra 4Sight XV6 unit

This chapter explains how to operate your Zebra 4Sight XV6, including how to connect peripherals to the unit.

Steps to get started

This section provides instructions on how to get started with your Zebra 4Sight XV6.

Operating Zebra 4Sight XV6 for the first time

Perform the following steps to operate Zebra 4Sight XV6 for the first time:

1. Connect your display device, keyboard, and mouse to the unit.

For information on where the connectors are found for these devices, refer to the *Connecting peripheral devices* section, later in this chapter.

2. Turn the unit on using the power switch on the front panel.

3. Once the unit boots, use the presented drop-down menu to select your language. Once you have selected the language, you cannot change your selection (you will have to reinstall the operating system to change the language).

❖ Note that Zebra 4Sight XV6 assumes that your keyboard language is the same as the language you selected.

4. Verify that your connected devices are operating correctly.

5. Once your devices are operational, you can power down the unit to connect devices to the motherboard. For information on adding hardware to the Zebra 4Sight XV6 motherboard, refer to *Chapter 3: Cleaning the air filter and adding devices to Zebra 4Sight XV6*.

6. Optionally, mount the unit to your equipment so that it isn't prone to being knocked off of its surface. For information, see *Zebra 4Sight XV6 mounting* section later in this chapter.

7. Connect any required peripheral devices.

Important

Turning off the Zebra 4Sight XV6 unit

To turn off the Zebra 4Sight XV6 unit, flip the power switch to off. You can also shut down the unit by shutting down Windows with the **Shut Down** command.

Rebooting the unit

When the unit is on, you can reboot the unit by pressing the **Control-Alt-Delete** keys on your keyboard simultaneously, or you can select the **Restart** option from the Windows Start menu.

If you need to enter the UEFI¹ Setup utility, you must press the **Esc** key during power-on self-test (POST). You only have a few moments to press the **Esc** key before the boot-up process continues.

1. On legacy computers, this was referred to as a BIOS, and in some menu items, BIOS and UEFI are still used interchangeably.

Zebra 4Sight XV6 mounting

The Zebra 4Sight XV6 unit comes with two external mounting brackets that can be attached to the unit. These brackets are used to attach the unit to shelves or other static parts of your production environment. It is recommended to use these brackets so that the Zebra 4Sight XV6 unit isn't prone to being knocked off of its surface.

To attach the mounting brackets, perform the following:

1. Decide how to attach both mounting brackets. The mounting brackets can be attached to the bottom or sides of the unit.

Zebra 4Sight XV6 side
mounting holes

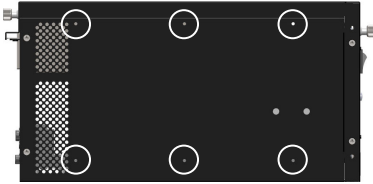

Zebra 4Sight XV6 bottom
mounting holes

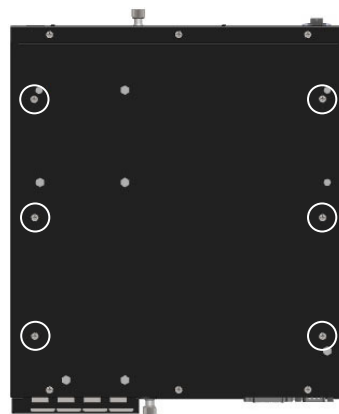

- Align the three holes on each bracket with the mounting holes on the Zebra 4Sight XV6 unit. Use the screws found in the mounting bracket bag to attach the mounting brackets to the Zebra 4Sight XV6 unit.

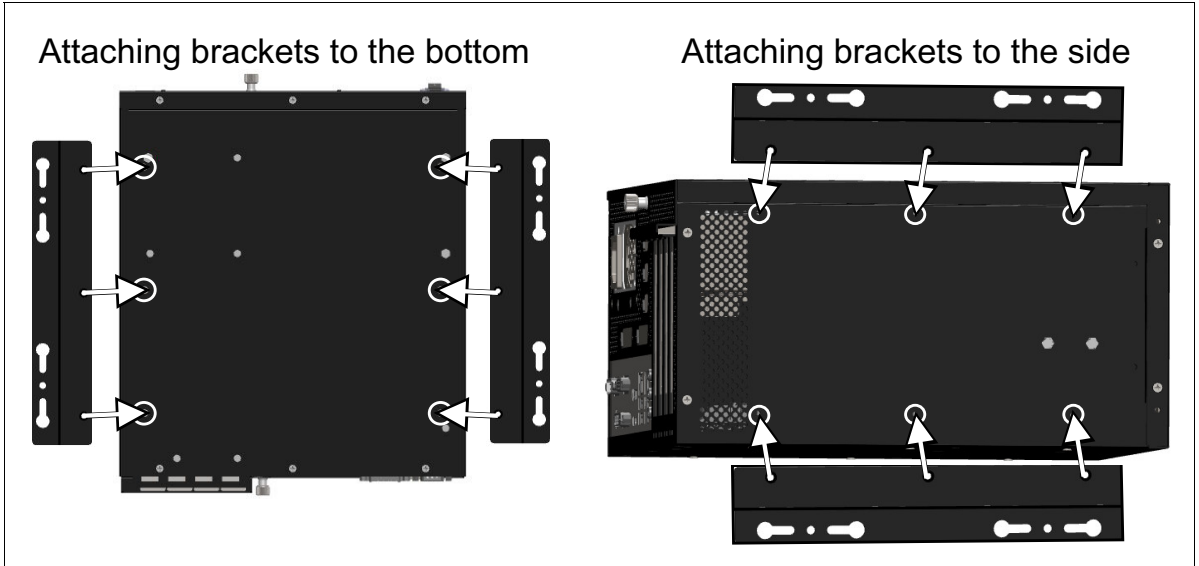

- Fasten the mounting brackets to your equipment using the key holes on the brackets. Use fasteners of appropriate size and length to mount securely. Ensure that Zebra 4Sight XV6 is mounted to equipment that is sturdy and durable (for example, metallic equipment).

Connecting peripheral devices

The following sections describe how to connect various devices to the external connectors of the Zebra 4Sight XV6 unit.

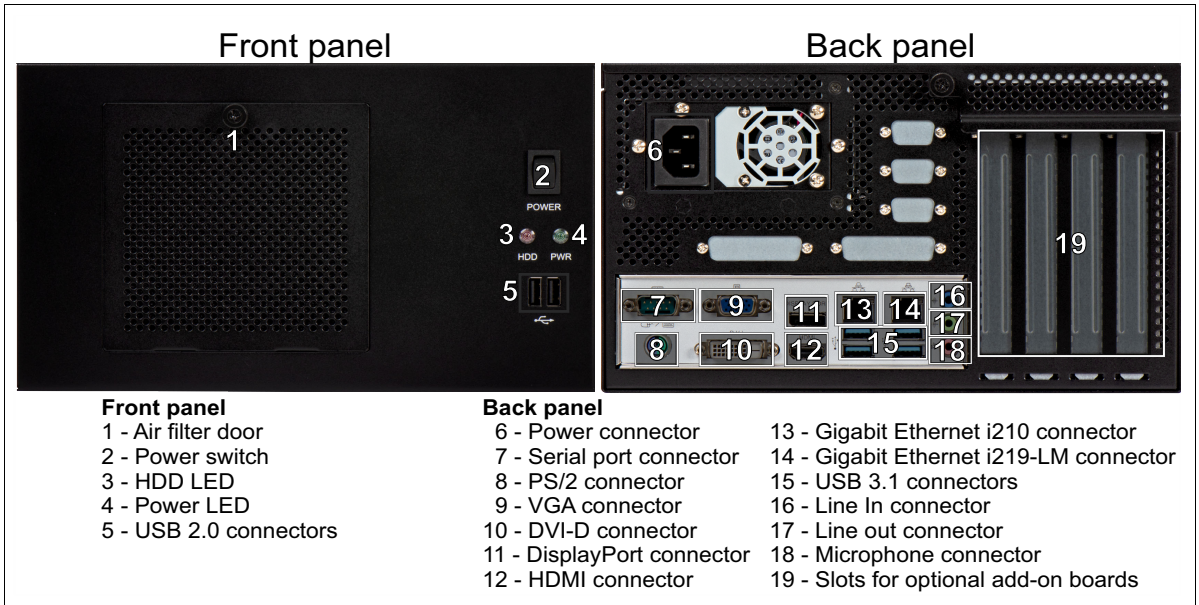

Caution

Be sure to turn off the power to the unit and all peripherals, as well as unplug the power from the unit before adding or removing devices.

Zebra 4Sight XV6 has connectors on its front and back panel to connect to the following devices:

- Six USB connectors are available to connect to devices such as USB3 Vision cameras, a USB mouse, a keyboard, a printer, or a flash drive. USB hubs can also be used to connect multiple USB devices to a USB connector. Typically, you connect your USB3 Vision cameras to the USB 3.1 connectors because they support speeds of up to 5 Gbps.

Warning

In environments where your Zebra 4Sight XV6 is subjected to vibrations, connect your third-party USB devices to your unit using locking cables.

- Two Gigabit Ethernet connectors¹ are available to connect to your enterprise network and possibly your industrial network or a GigE Vision camera. The left Ethernet connector has an I210 network interface and the right Ethernet connector has an I219-LM network interface. The I219-LM Gigabit Ethernet connector provides Wake-on-LAN (WoL) and Intel Active Management Technology (AMT) for remote management.
- Four video output connectors to which you can connect up to 3 display devices:
 - You can connect one high-resolution analog display device (such as an analog monitor or analog flat panel) to the VGA connector.
 - You can connect a high-resolution digital display device (such as a digital flat panel) to each of the DVI-D, HDMI, or DisplayPort connectors. The DisplayPort connector is version 1.2 and the HDMI connector is version 1.4.
- One PS/2 connector to which you can connect a PS/2 mouse or keyboard.
- Three 1/8" mini plugs used for audio input, audio output, and a microphone.

To connect additional cameras or other types of cameras, you can install a frame grabber in the unit. See *Connecting peripheral devices* section, in *Chapter 2: Getting started with your Zebra 4Sight XV6 unit*.

1. Note that PoE is not supported.

Networking connections

You can connect Zebra 4Sight XV6 to your local area network (LAN), via Gigabit Ethernet (1000 BaseT), or Fast Ethernet (100 BaseT). To do so, connect a network cable to one of the two Gigabit Ethernet connectors, located on the back panel of the chassis. The Ethernet connector on the left has an I210 network interface. The Ethernet connector on the right has an I219-LM network interface.

The I219-LM Gigabit Ethernet connector provides Wake-on-Lan (WoL) and Intel Active Management Technology (AMT) for remote management. To enable the WoL feature, you must modify settings in your UEFI¹. In the UEFI, navigate to the ACPI configuration section and enable "PCIe Devices Power On".

Required cabling for Ethernet connections

To make the connection, use an appropriate network cable. The required type of network cable depends on the type of connection:

Connection	Minimum category for network cable
Gigabit Ethernet	Category 5e (CAT5e)/ Category 6 (CAT6) cable
Fast Ethernet (100 Mbits/sec)	Twisted Pair Category 5 (UTP5) cable
10 Mbits/sec	UTP5/UTP3 cable

An RJ45 connector (shown below) must be attached to each end of the cable.

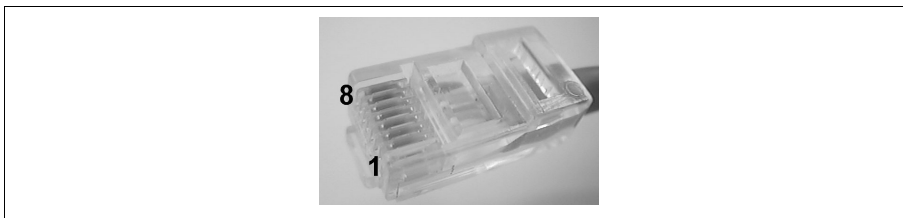

Each of the Gigabit Ethernet connectors on Zebra 4Sight XV6 has 2 LEDs to convey network activity and speed information. For information on how to read the LEDs, see the *Light emitting diodes (LEDs)* section, in *Appendix B: Technical reference*.

1. On legacy computers, this was referred to as a BIOS, and in some menu items, BIOS and UEFI are still used interchangeably.

Chapter

3

Cleaning the air filter and adding devices to Zebra 4Sight XV6

This chapter deals with additions that can be made to Zebra 4Sight XV6.

Overview

This chapter explains how to clean the air filter in your Zebra 4Sight XV6, and how to connect various devices to the Zebra 4Sight XV6 motherboard.

Cleaning the air filter

The Zebra 4Sight XV6 unit contains a polyurethane air filter. The air filter prevents dust and dirt from entering the unit. To ensure efficient cooling of the Zebra 4Sight XV6 unit, you must regularly clean the air filter as follows:

1. Before cleaning, turn off the Zebra 4Sight XV6 unit and unplug the power cord.
2. Using a household vacuum, turned on at a low setting, position the vacuum nozzle in front of the air vents on the front panel of Zebra 4Sight XV6. Excess dust and particles will be safely removed through the air vents.

Removing the Zebra 4Sight XV6 chassis cover

Follow the steps listed below to remove the chassis cover.

Important

1. Power Zebra 4Sight XV6 down and unplug the Zebra 4Sight XV6 power cord.
2. Unscrew the knob on the Zebra 4Sight XV6 unit's back panel (see the following illustration)

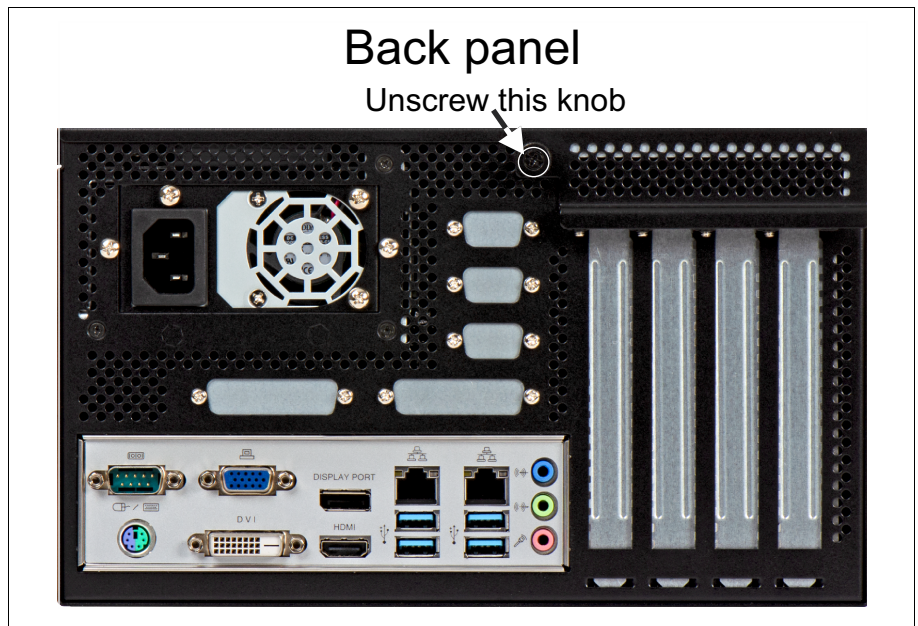

3. Slide the cover back and pull up to remove the lid.

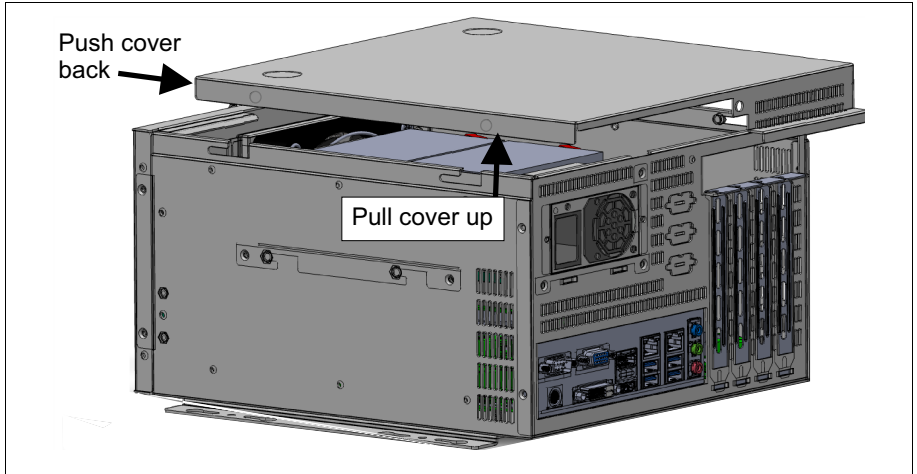

Warning

Once you have removed the cover and exposed the motherboard, do not touch the heat sink or fans while the unit is running, or soon after the unit has been turned off; they might be very hot.

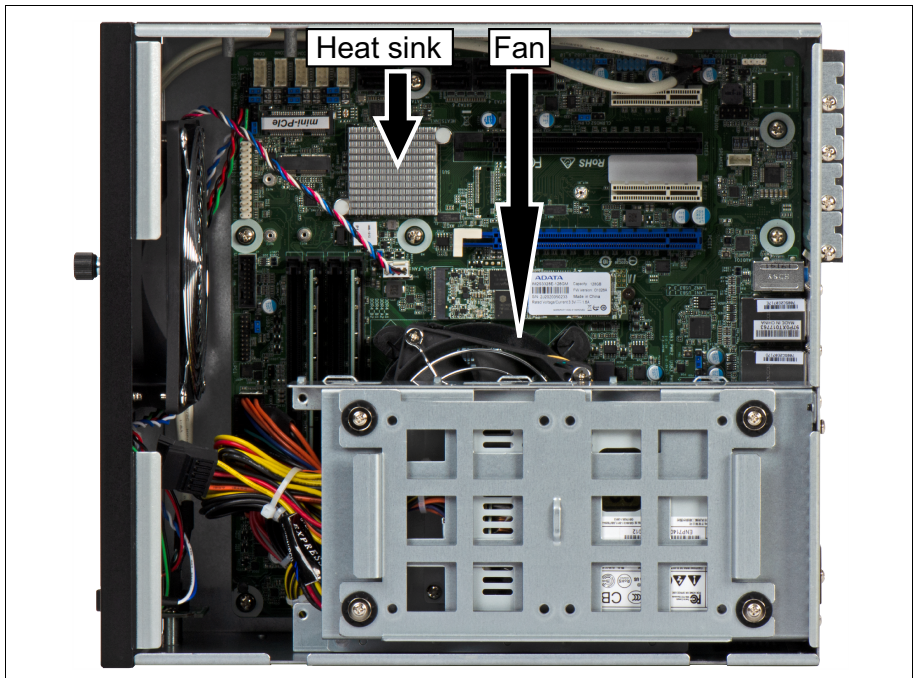

Devices that can be added to your Zebra 4Sight XV6 motherboard

Zebra 4Sight XV6 is designed to accommodate selected hardware additions. The Zebra 4Sight XV6 motherboard has connectors to connect the following devices:

- Eight SATA3 data connectors for connecting additional mass storage devices. For information on how to connect devices to the SATA3 data connectors, see *Connecting a device to the SATA3 data connectors* section later in this chapter.
- Two M.2 sockets, one is E-Key and one is M-Key. The M-Key connector already has a 120 Gbyte SSD attached to it. For information on how to install a mini-board to one of the M.2 sockets, see *Replacing the M.2 SSD attached to the M.2 socket* section later in the chapter.
- Four PCIe 3.0 connectors for connecting Zebra (or third party) full-height, half-length add-on boards. For example, you can connect frame grabbers, digital I/O boards, and/or a Zebra board that supports hardware-assisted PROFINET communication (for example, Zebra Indio). For information on how to install add-on boards to the PCIe connectors, see *Installing full-height, half-length PCIe boards* section later in the chapter
- One mini-PCIe connector for connecting a mini-PCIe add-on board.
- Four 288-pin Long-DIMM memory slots. One or two memory modules, with a total of 8 or 16 Gbytes of memory combined, come pre-installed in the slots, depending on what was ordered. For information on how to install Long-DIMM memory slots, see *Installing or removing RAM* section later in the chapter.

The following diagram provides a reference to motherboard connectors.

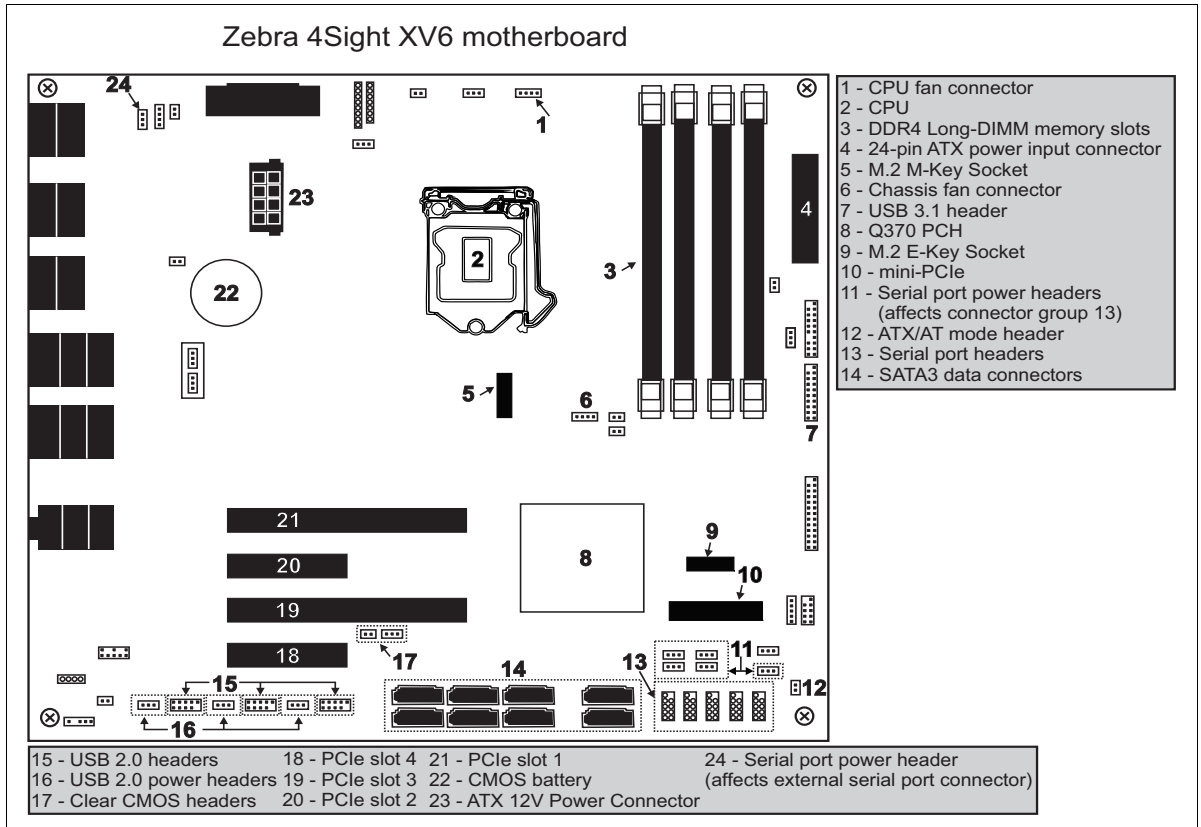

Installing full-height, half-length PCIe boards

The Zebra 4Sight XV6 motherboard has the following PCIe connectors, which allow you to connect up to four Zebra (or third-party) full-height, half-length PCIe boards to your Zebra 4Sight XV6:

Slot #	Description
1	PCIe 3.0 x16* (only x8 if slot 3 is used)
2	PCIe 3.0 x4 (open-ended)
3	PCIe 3.0 x8 * (mechanically x16)
4	PCIe 3.0 x4 (open-ended)

*. The first PCIe 3.0 x16 connector (slot 1) will operate at a x8 width when a board is present in the second PCIe 3.0 x16 connector (slot 3). The second PCIe 3.0 x16 connector (slot 3) is electrically wired as a PCIe x8 slot, so PCIe x16 boards will operate at a maximum of PCIe x8.

❖ Note that, depending on the slot in which you install the board, it might not operate at full width of the slot.

Zebra 4Sight XV6 supports PCIe boards with a single or a double bracket. You can install four boards with a single bracket, or two boards with a double bracket.

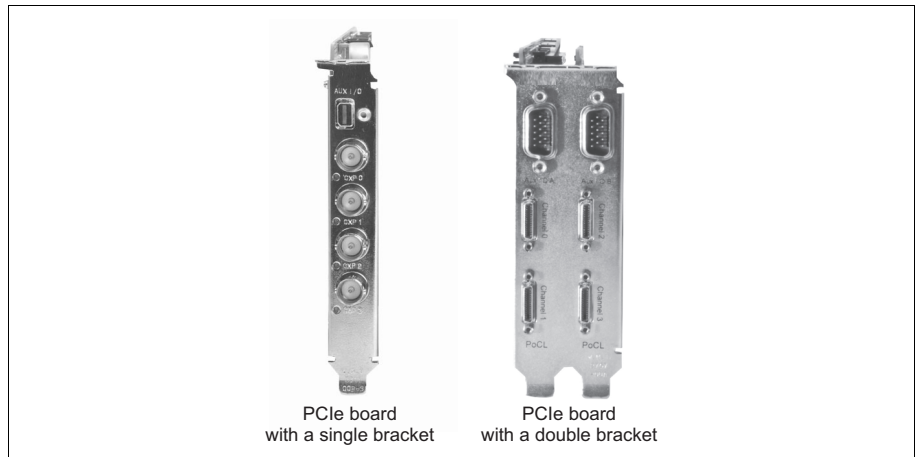

To connect your PCIe board to the motherboard, follow the steps below:

1. Remove the chassis cover. For instructions, refer to *Removing the Zebra 4Sight XV6 chassis cover* section, earlier in this chapter.
2. Using a Phillips #2 screw driver, remove the metal cover from the appropriate slot's opening on the back panel of your Zebra 4Sight XV6.
3. Ensure that the PCIe locks are open before installing or removing a board, and closed once the board is installed.

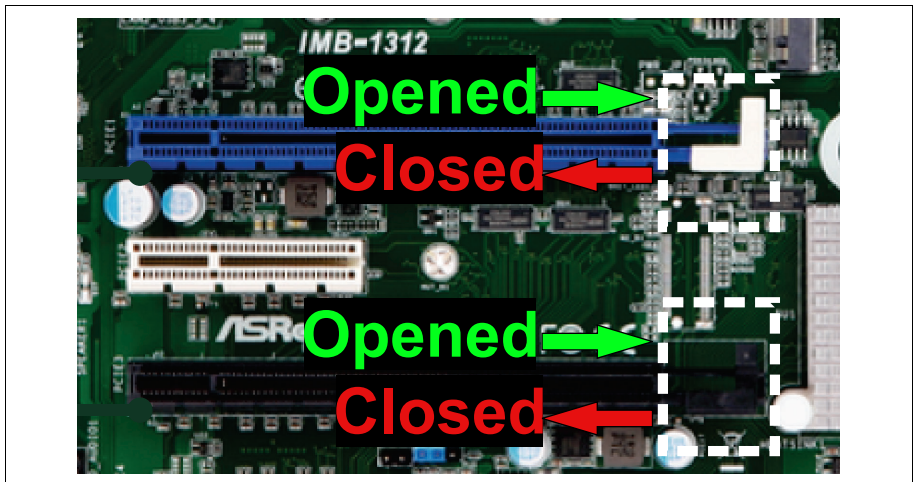

4. Position your PCIe board in the selected slot, as illustrated below.

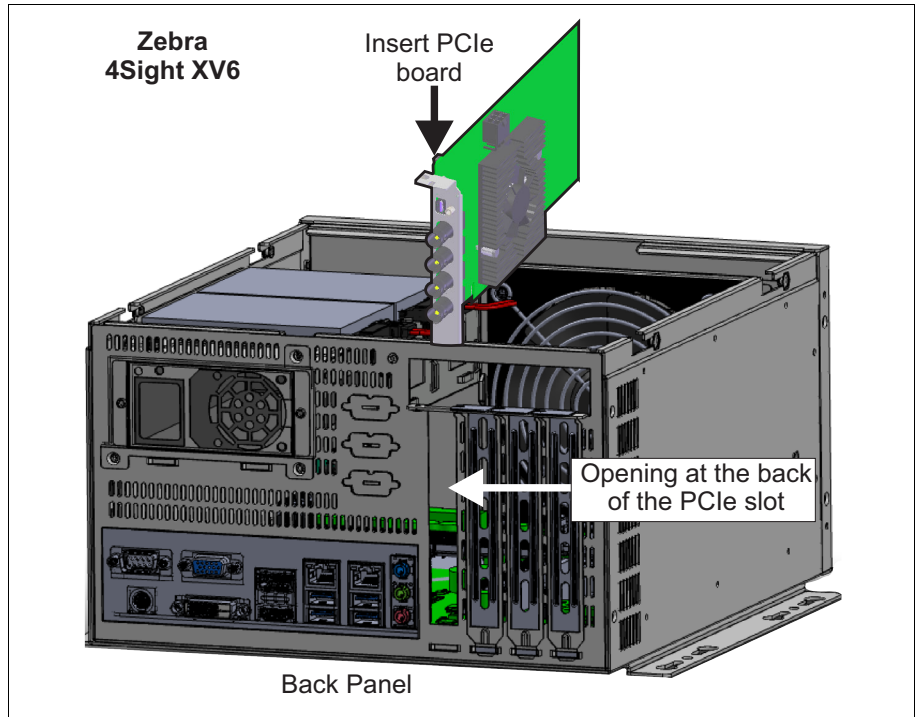

5. Press the board firmly but carefully straight down into the connector of the slot.
6. Close the PCIe locks (as illustrated on the previous page). Remember to reopen them if you need to uninstall the board(s).
7. If required by the add-on board, you can connect it to auxiliary power. There are two 15-pin SATA power connectors and two 6+2 pin PCIe power connectors available from the power supply for auxiliary power. See *Electrical specifications* section, in *Appendix B: Technical reference* for more information.

Connecting a device to the SATA3 data connectors

Besides the M.2-connected solid state drive (SSD) pre-installed in the unit, the Zebra 4Sight XV6 motherboard provides eight 7-pin SATA3 data connectors for connecting additional storage devices, such as hard disk drives or solid-state drives (SSDs). If you chose to connect a device to one of these connectors, note that the unit only has space for a maximum of two SATA 2.5" HDD or SSD devices up to 9.5 mm thick. In addition, SATA3 connector 1 is shared with the M.2 M-key socket; therefore, this connector is unusable when the M.2 SSD is installed.

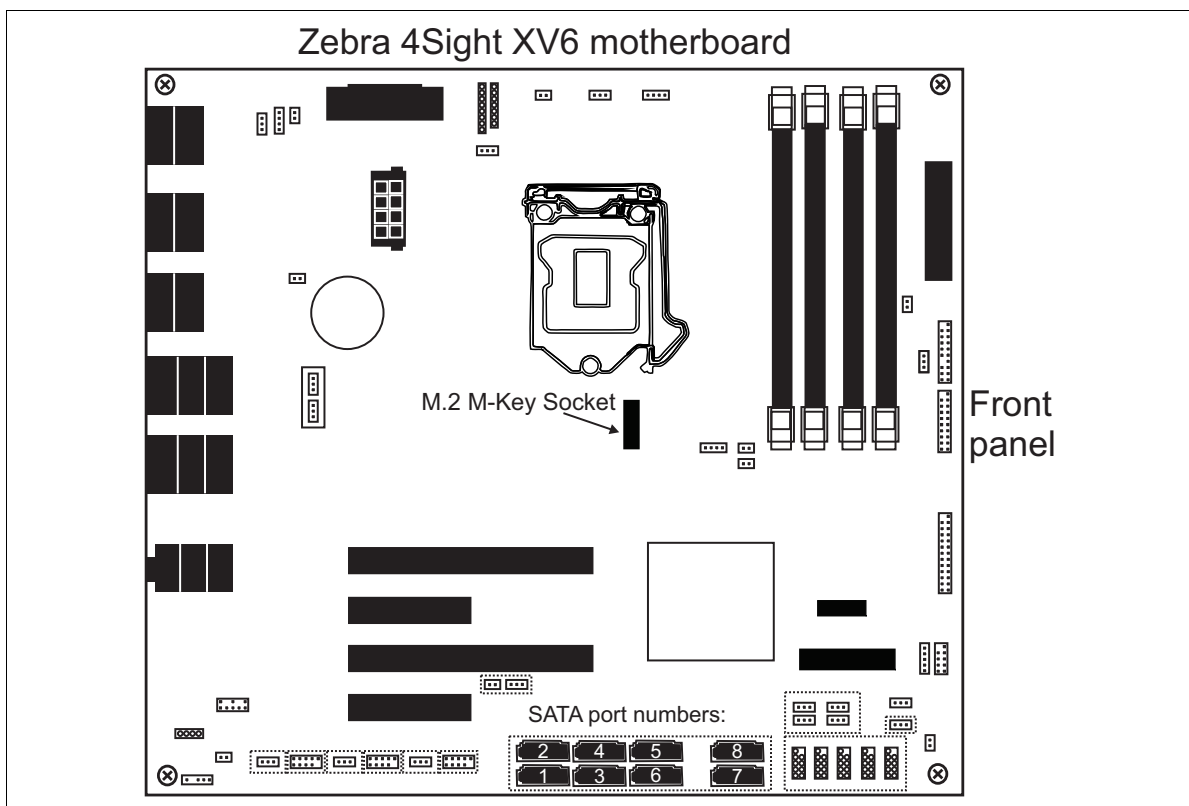

Drive assignments

When you connect a mass storage device to one of the 7-pin SATA3 data connectors, the operating system and UEFI¹ identify it by the SATA connector (port) to which it is connected. SATA3 data connector 1 is to the left of connector 2 when facing the front panel of the unit.

- ❖ Note that, SATA connector 1 is shared with the M.2 module and it is therefore unusable when an M.2 module is installed.

Replacing the M.2 SSD attached to the M.2 socket

An M.2 SSD comes pre-installed in the Zebra 4Sight XV6 unit's M.2 M-key socket. This SSD comes pre-loaded with your software and licensing. You should make a backup of this SSD before replacing it.

To replace the M.2 SSD in the Zebra 4Sight XV6 unit, perform the following:

Important

1. Unplug the power supply from your unit.
2. Remove the chassis cover. To see instructions on how to do so, refer to *Removing the Zebra 4Sight XV6 chassis cover* section, earlier in this chapter.
3. Remove the screw that holds the M.2 SSD to the motherboard. The board will spring up at a 20 degree angle. Pull the board out at the same angle.

1. On legacy computers, this was referred to as a BIOS, and in some menu items, BIOS and UEFI are still used interchangeably.

4. Slip the edge of the new M.2 SSD into the connector from which you removed the previous mass storage device. The connecting edge will fit neatly into the socket, leaving the board at a 20 degree angle from the motherboard.

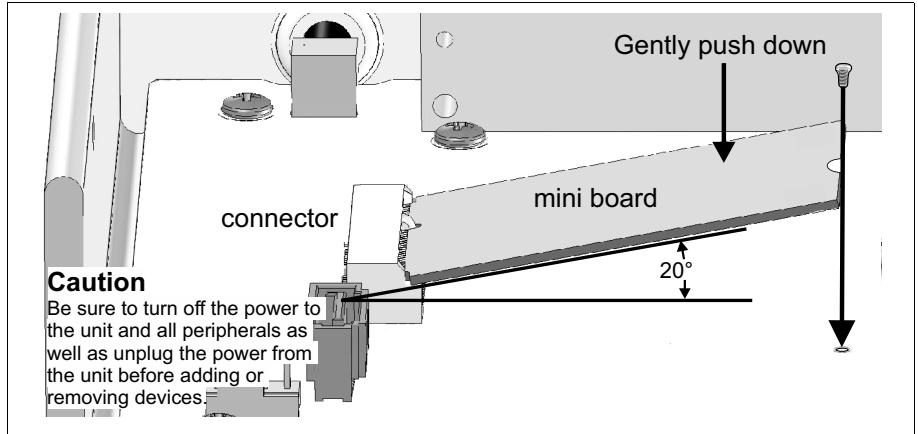

5. Press the mass storage device down and attach it to the motherboard with the same screw you removed in step 3.
6. Once the SSD is seated, reassemble the case.
7. Reconnect the power to your unit.
 - ❖ Note that, the M.2 SSD will draw its power directly through the motherboard.
8. After your Zebra 4Sight XV6 boots, run the UEFI Setup program to verify that the SSD is identified correctly.

Installing or removing RAM

The Zebra 4Sight XV6 motherboard features four 288-pin Long-DIMM slots in which you can install random access memory (RAM) modules. Each slot can support one DDR4 2400/2666 Mbps SDRAM module up to 16 Gbytes in size. Zebra 4Sight XV6 supports 1.2 V, unbuffered, PC3-12800-compliant DDR4 SDRAM. Contact Zebra for a list of supported modules.

- ❖ Note that the motherboard supports dual-channel memory technology. This means that for optimal performance and reliability, when installing new memory modules, you should install the modules in pairs, starting with slots A0 and B0. Install identical memory modules in slots A0 and B0 and identical memory modules in slots A1 and B1. Mixing different models is not recommended.

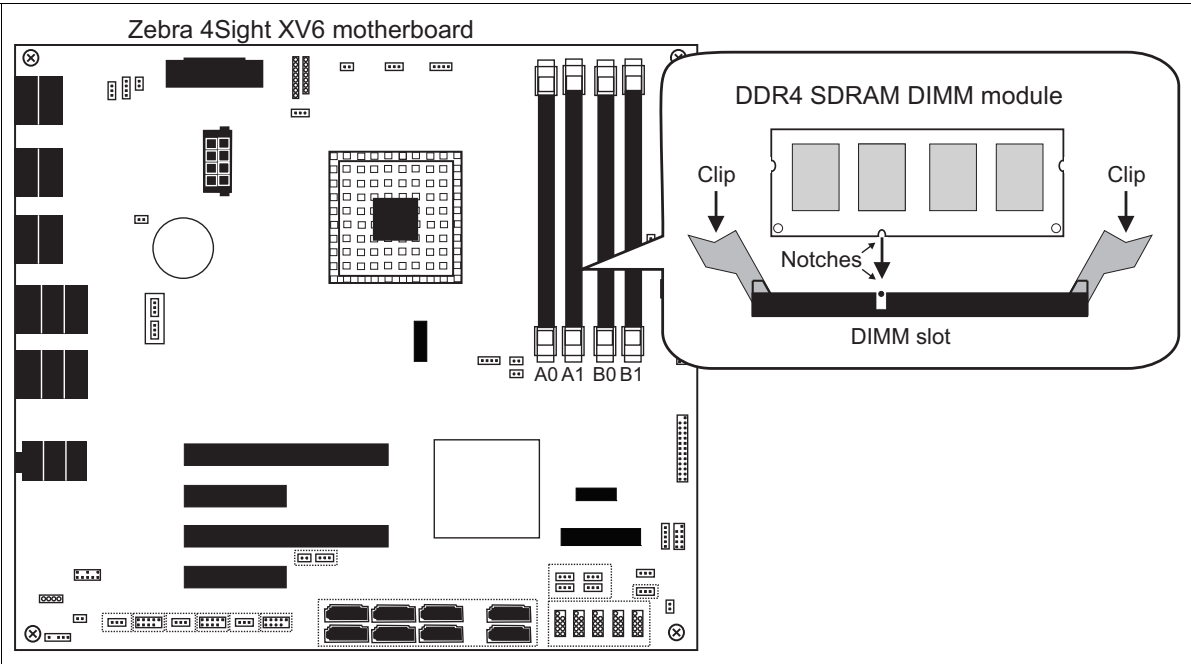

Installing memory

To install a memory module in the Zebra 4Sight XV6 unit:

1. Ensure that the clips at each end of the Long-DIMM slot are spread.
2. Position the module over the Long-DIMM slot, such that the notch along the module's bottom edge is aligned with the notch of the Long-DIMM slot. If installing additional memory modules, ensure they are the same model as the ones already installed.
3. Gently insert the bottom edge of the module into the slot.
4. Carefully close the two clips over the side notches of the module.

Removing memory

To remove a memory module from the Zebra 4Sight XV6 unit:

1. Spread the clips at each end of the Long-DIMM slot.
2. Lift the module out of the slot.

Adjusting the new memory settings

After installing memory in your Zebra 4Sight XV6, you must adjust the unit's new memory settings using Aurora Imaging Configurator. Refer to the Aurora Imaging Library User Guide for more information on using this utility.

Appendix A:

Hardware glossary

This appendix defines some of the specialized terms used in the Zebra 4Sight XV6 documentation.

Glossary

- **Bandwidth.**

A term describing the capacity to transfer data. Greater bandwidth is needed to sustain a higher transfer rate. Greater bandwidth can be achieved, for example, by using a wider bus.

- **Bus.**

A pathway along which signals are sent, generally in two directions, for communication of data.

- **Cache.**

A memory area of the processor. The processor can access data from its cache faster than it can access data from system RAM or mass storage devices.

Many processors have a *primary* cache and a *secondary* cache. When searching for information, the processor first refers to the primary cache. If it cannot find the required information, it will then refer to the secondary cache.

- **Contiguous memory.**

A block of physical memory occupying a single, consecutive series of locations.

- **DDR4 SDRAM.**

Double data rate four synchronous dynamic random access memory. A type of RAM used for image capture and processing.

See also *RAM*.

- **DHCP.**

Dynamic host configuration protocol. A DHCP server automatically assigns IP addresses to clients who log onto a TCP/IP network. It eliminates the need to manually assign and manage unique IP addresses for all of the machines on a network.

- **DIMM.**

Dual in-line memory module. A DIMM is a memory module with integrated circuitry. Long-DIMM modules are typically used in embedded devices and desktop computers.

See also *RAM*.

- **Ethernet.**

The most common standard for the physical wiring and signalling on a local area network (LAN). The Gigabit Ethernet LAN supports data transfer at rates of 10, 100, or 1000 Mbits/sec.

See also *LAN*.

- **Ethernet cable.**

A wire similar to a telephone cable that carries the signals between Ethernet devices.

- **Frame.**

A single image grabbed from a video source.

- **Full-duplex mode.**

A communication method that involves sending and receiving information simultaneously. For example, a switch can operate in full-duplex mode.

- **Grab.**

To acquire an image from a video source.

- **Half-duplex mode.**

A communication method that involves sending or receiving information. However, this cannot be done simultaneously. For example, all hubs operate in half-duplex mode.

- **Host.**

In general, Host refers to the principal processor in one's computer.

- **IP address.**

Internet protocol address. The electronic address of a computer (station) on a TCP/IP network, which is unique for every client and server station. Client workstations have either a permanent or dynamically assigned address. The IP address is a dot address that is written as four sets of numbers separated by periods, also called dotted quad notation (for example, 203.142.62.2). The TCP/IP packet uses 32 bits to hold the IP address.

- **LAN.**

Local area network. A LAN is a group (or network) of computers and other devices that are connected together to share the resources (files, printers, devices, and other services such as internet access) of a single workstation or server within a small geographical area. The main LAN connection technology used is Ethernet cable, which connects users (clients) to the LAN's server. Clients download applications and/or services from the server, and then run or use them from their local computer.

- **Network bindings.**

The series of associations that enable communication among the network services, protocols, and adapters in your computer. In this case, "binding" refers to the conversion or association of symbolic addresses in the operating system to storage-related addresses. These associations can be adjusted to increase the performance of certain network services among multiple network adapters.

❖ Note that you should not adjust network bindings unless you are an experienced network administrator and are familiar with the requirements of your network software.

- **PCIe.**

Peripheral Component Interconnect Express. The standard used for the computer bus that acts as an interface between hardware devices, such as an add-on board and your Zebra 4Sight XV6.

- **POST.**

Power-on self test. This test is performed by the UEFI, as soon as the computer is turned on. POST gathers information about what the unit contains, and ensures that everything is working properly. It works by performing a list of tasks related to testing the RAM, the on-board hardware, the add-on boards, the keyboard, the hard disk drives, and other installed components. If all the tasks are completed, the UEFI will proceed to boot the operating system. If a task cannot be completed, POST will report an error to the UEFI, and a message will be displayed.

- **Protocol.**

A set of standards (rules/formats) for transmitting information “packets” between computer software and hardware devices. Information packets are structured according to the standards of a protocol. On a network, the data link or Media Access Control protocol standard, such as the CSMA/CD standard, provides the access method, and TCP/IP provides the control and routing method to transmit (move) information packets.

- **RAM.**

Random access memory. RAM is memory in which the operating system, application programs, and data in current use are stored so that they can be accessed by the processor. Information stored in RAM is lost when power is cut off. RAM chips can be typically installed on a memory module (such as a DIMM memory module) that is plugged into the motherboard.

- **Subnet mask.**

The sequence of numbers that the router uses to determine which parts of the 32-bit IP address is specific to the subnetwork (that is, common to all of the machines on the network) and should be used for transmitting the information “packet” to the subnetwork. This mask saves the router from having to handle the entire 32-bit IP address; instead, it can look at only the bits enabled (set to “1”) by the mask. For example, if the network and subnet addresses are contained in the upper 24 bits, and the specific Host address is contained in the lower 8 bits, then you can convey this information to the router to allow quicker transmission to the subnet by passing the following mask value: 255.255.255.0 (11111111.11111111.11111111.00000000).

- **TCP/IP.**

Transmission control protocol/internet protocol. The basic communication protocol (or language) of the internet that has become the global standard for network communications since it ensures faithful data transmission. TCP/IP uses the *client-server* communication model, in which a computer user (client) makes requests and is provided services by a network computer (server).

TCP/IP is a multi-layered protocol. In the transport layer, TCP ensures delivery of the entire file/message. TCP manages the assembly of files/messages into “packets” that are transmitted to and received by another TCP layer. That TCP layer then reassembles the packets into its original format. In the network layer, IP routes the data to different destinations (LANs or WANs) based on the network address. TCP/IP is a routable protocol, which ensures that all messages contain the address of both the destination computer (station) and destination network. This makes it possible for messages to be transmitted to multiple networks.

- **UEFI.**

Unified Extensible Firmware Interface. The interface between the operating system and the hardware. It is also responsible for booting the operating system when a unit is turned on. On legacy computers, this was referred to as a BIOS, and in some menu items, BIOS and UEFI are still used interchangeably.

Appendix B:

Technical reference

This appendix summarizes the key features of the Zebra 4Sight XV6 unit. In addition, this appendix provides descriptions for external and internal connectors of the Zebra 4Sight XV6 unit.

Summary

Motherboard

- Micro-ATX based form factor, 9.6" x 9.6" (24.38 cm x 24.38 cm).
- One of the following processors:
 - Intel i5-8500 processor with 6 cores that can run at 3 GHz or up to 4.1 GHz in Turbo mode and with a 9-Mbyte cache.
 - Intel Celeron G4900 processor with 2 cores that can run at 3.1 GHz with a 2 Mbyte cache.
- Intel Platform Controller Hub (PCH) Q370 Express chipset (combined northbridge and southbridge).
- Supports up to three display devices, which can be connected to 3 of the 4 video output connectors: DVI-D, HDMI, DisplayPort, and VGA. The video output connectors support the following maximum resolutions:

Connector	Maximum resolution
VGA	1920 x 1200 @ 60 Hz
DVI-D	4096 x 2304 @ 60 Hz
HDMI version 1.4	4096 x 2160 @ 24 Hz
DisplayPort version 1.2	4096 x 2304 @ 60 Hz

The XV6I5M32CT model includes a pre-installed GPU board.

- Two Gigabit Ethernet interfaces that use standard RJ-45 Ethernet connectors¹. One uses an I210-IT Gigabit Ethernet controller, while the other uses an I219-LM controller. Each supports 10 /100/1000 Mbps connections.
- Twelve USB interfaces. There are two USB 2.0 connectors on the front of the unit and four USB 3.1 connectors on the back. Inside the unit on the motherboard, there are three USB 2.0 headers² and one USB 3.1 header, each of which support two USB ports per header.

1. PoE is not supported on either Ethernet connector.

- One serial port connector on the outside of the unit; you can connect a device through either the RS-232, RS-422, or RS-485 standard. There are also five additional RS-232 serial port headers available on the motherboard inside the unit.
- One PS/2 (keyboard or mouse) port. You can connect a keyboard or a mouse that uses a PS/2 port.
- Support for stereo audio input, output, and a microphone.
- Four PCIe 3.0 slots.

Slot #	Description
1	PCIe 3.0 x16* (only x8 if slot 3 is used)
2	PCIe 3.0 x4 (open-ended)
3	PCIe 3.0 x8 * (mechanically x16)
4	PCIe 3.0 x4 (open-ended)

*. The first PCIe 3.0 x16 connector (slot 1) will operate at a x8 width when a board is present in the second PCIe 3.0 x16 connector (slot 3). The second PCIe 3.0 x16 connector (slot 3) is electrically wired as a PCIe x8 slot, so PCIe x16 boards will operate at a maximum of PCIe x8.

- One mini-PCIe slot. Can be used to connect full and half sized PCIe x1 boards and USB 2.0 devices.
- Two M.2 sockets. One is E-Key with support for PCIe x1, CNVI, and USB 2.0 for wireless. The second is M-Key and is used to connect the 120 GB SSD.
- Four 288-pin Long-DIMM slots supporting dual-memory channel DDR4-2400/2666 Mbps RAM. Each slot supports a memory module up to 16 Gbytes in size.
- Eight SATA3 data connectors. One SATA3 data connector is shared with the M.2 M-Key socket.

-
2. The external 2.0 USB connectors are connected to one of the internal USB 2.0 headers.

Memory

Zebra 4Sight XV6 supports 1.2 V, unbuffered, PC3-12800-compliant Long-DIMM DDR4 SDRAM. Zebra 4Sight XV6 ships with either one or two 8-Gbyte DDR4 SDRAM modules that are non-ECC Long-DIMM, and run at 2400 Mbps or 2666 Mbps. The XV6I5M32CT model comes with two 16-Gbyte DDR4 SDRAM modules.

- ❖ Note that, the Intel processor installed in your Zebra 4Sight XV6 follows the JEDEC memory specification. The specified voltage for DDR4 memory, according to JEDEC specification, is 1.2 V. Therefore, you must only use DDR4 memory modules that can be powered at 1.2 V.

Default storage drive

- M.2 solid state drive (SSD).
- Minimum storage capacity: 120 Gbytes.
- The XV6I5M32CT model includes a second 2.5' SSD.
- ❖ Note that drive specifications are subject to change without notice.

Fans

The fans, which are used to cool the unit, operate at speeds controlled by the on-board fan controller, based on the temperatures of the processor and the motherboard.

- ❖ Note that when the unit is first turned on, or restarted, the fans will initially operate at their maximum speed.

Air filter

The Zebra 4Sight XV6 unit contains a polyurethane air filter. The air filter will need to be cleaned on a regular basis. If you operate your Zebra 4Sight XV6 in a dusty environment, you might notice that the unit is overheating, or that the fan is running faster and noisier than usual. These are indicators that the filter needs to be cleaned. For information on how to clean it, refer to the *Cleaning the air filter* section, in *Chapter 3: Cleaning the air filter and adding devices to Zebra 4Sight XV6*.

Environmental specifications

- Minimum/maximum ambient operating temperature: 0 to 45°C (32 to 113°F).
- Minimum/maximum storage temperature: -40 to 85°C (-40 to 185°F).
- Operating altitude: up to 2000 meters.
- Operating humidity: 10 to 90% (non-condensing).
- Storage humidity: 5 to 95% (non-condensing).
- Pollution degree 2 environment.
- Designed for indoor use only.

Electrical specifications

The power supply has the following specifications:

	Zebra 4Sight XV6
Power supply	400 W
AC input	5-2 A (nominal), 100 - 240 V _{ac} , 47 - 63 Hz
DC output	<ul style="list-style-type: none"> • +3.3 V_{dc}, 17 A • +5 V_{dc}, 14 A • +5 V_{standby}, 2.5 A • +12 V1_{dc}, 18 A • +12 V2_{dc}, 18 A • -12 V_{dc}, 0.3 A • Max power for +3.3 V, +5 V, 90 W for both power rails combined
Supplemental power connectors	<ul style="list-style-type: none"> • Two 15-pin SATA Power (+12 V1_{dc} 6 A, +5 V_{dc} 6 A, and +3.3 V_{dc} 6 A). • One 4+4 pin EPS (+12 V2_{dc} 24 A). • Two 6+2 pin PCIe 150W power (+12 V1_{dc}, 12.5 A, for each harness using the 6-pin and 2-pin connectors together, limited to 6.25 A when only using the 6-pin connector).

Warning:

- In addition to the PSU power limits documented on the PSU and in the manual, the wires in the cable harness, used to bring power to motherboard components and computer peripherals, have a current rating that must be met at all times for each individual wire in the harness.
- The unit ships with a number of cables in the PSU harness already connected to the motherboard and peripherals. These cables should not be disconnected by the user.
- The use of cable splitters or cable adapters that would allow exceeding the current rating of the harness should not be used.
- Only use the cable adapters in the accessory kit supplied with the unit.
- Before connecting power to user add-in board and peripherals, make sure the unit is off and the AC cord is disconnected.

Mise en garde:

- En plus des limites documentées sur le bloc d'alimentation et dans le manuel, chacun des fils et des câbles des harnais, utilisés pour alimenter les composantes de la carte mère ainsi que les périphériques de l'ordinateur, ont des spécifications en courant qui doivent être rencontrées en tout temps.
- L'unité est expédiée avec certains des câbles du bloc d'alimentation déjà connectés à la carte mère et aux périphériques. En aucun cas ces câbles ne doivent être déconnectés par l'utilisateur.
- L'utilisation de câbles adaptateurs pour fins de duplication du harnais ou permettant d'en excéder leur capacité en courant ne sont pas permis.
- N'utilisez que les câbles adaptateurs fournis en accessoires avec l'unité.
- Avant de connecter tout câble d'alimentation aux périphériques ou aux cartes, s'assurer que l'unité est éteinte et que le câble d'alimentation secteur est débranché.

Chassis

Zebra 4Sight XV6 has a rugged, heavy-duty steel chassis with mounting points that allow mounting the unit to other equipment or sturdy surfaces.

- Length: 11.97" (30.4 cm).
- Width: 10.32" (26.2 cm).
- Height: 6.10" (15.5 cm).

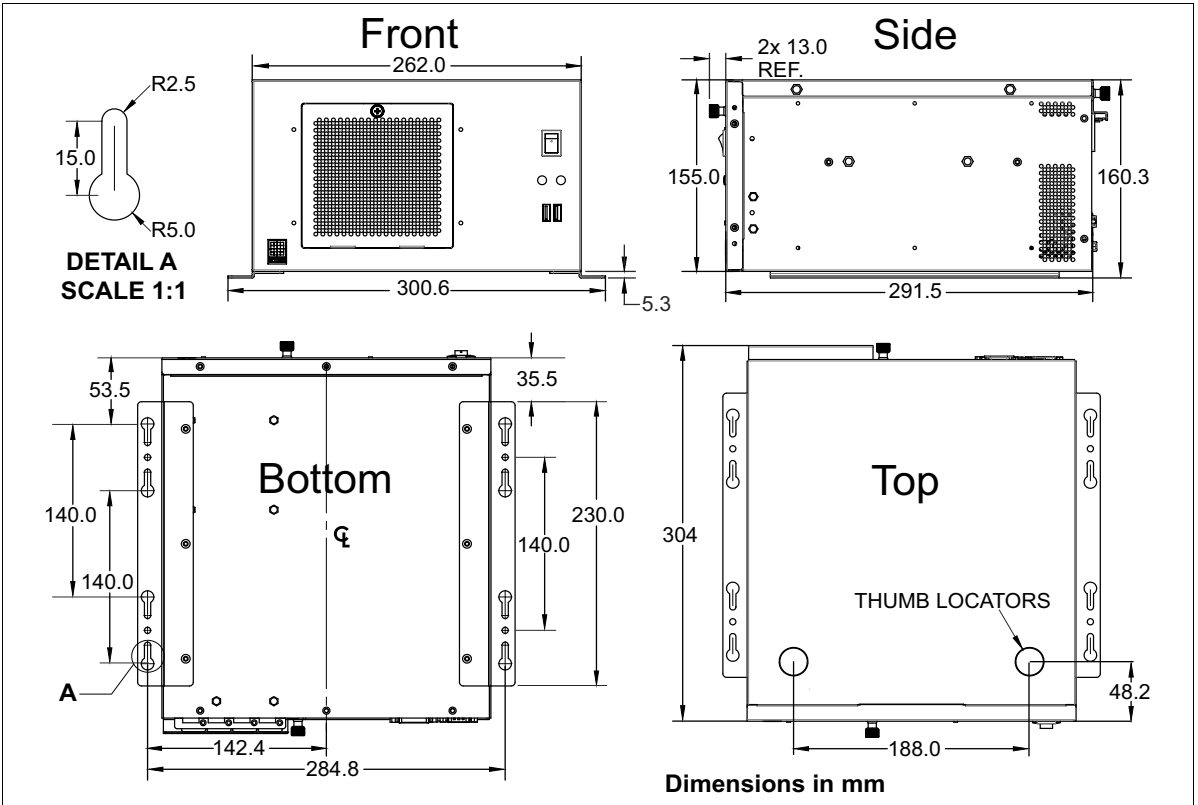

Coin cell battery/Pile bouton

- Used to maintain time and date settings of the unit's real-time clock.

Utilisée pour maintenir l'heure et la date de l'unité.

- Battery voltage: 3 V.

Voltage de la pile: 3 V.

- Diameter (max): 20 mm.

Diamètre (max): 20 mm.

- Battery type: CR2032.

Type de pile: CR2032.

Light emitting diodes (LEDs)

There are a total of six LEDs on the Zebra 4Sight XV6 unit.

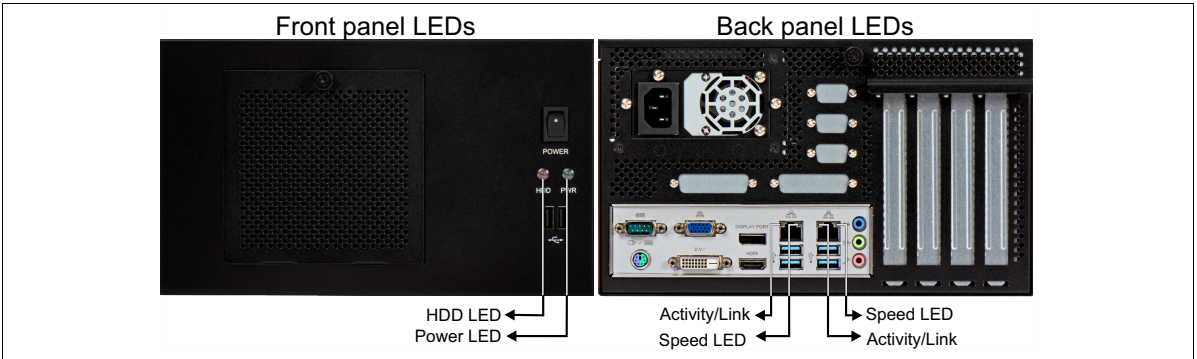

The following table describes the LEDs of each connector:

LED	Description
HDD LED	Turns green when any mass storage drive is active.
Power LED	Turns red when Zebra 4Sight XV6 is receiving power and turned on.
Activity/Link LED	Turns on when connected to a network.
	Blinks whenever packets are being transmitted or received.
	Turns off when no network connection is present.
10/100/1000 LED	Turns orange when operating in 100 BaseT mode.
	Turns green when operating in 1000 BaseT mode.
	Turns off when one of the following conditions is true: <ul style="list-style-type: none"> No network connection is present. The unit is operating in 10 BaseT mode. If the unit is operating in 10 BaseT mode, the Activity/Link LED will be solid or blinking.

Descriptions of external connectors

The Zebra 4Sight XV6 unit features the following external connectors:

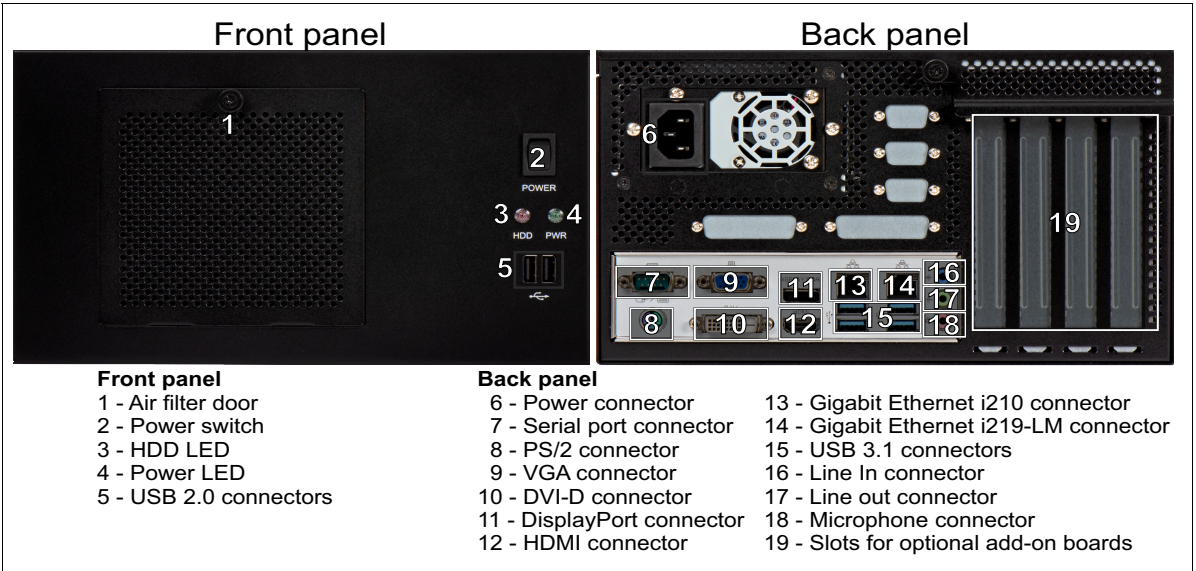

USB 2.0 connectors

The 2 USB 2.0 connectors on the front panel are standard rectangular, Series “A”, 4-pin receptacles. The USB 2.0 interfaces run at 480 Mbps. The pinout of these standard connectors is described in the USB Specification v2.0 from the USB Implementers Forum.

- Operating voltage and maximum current: 5 V, 500 mA.
- Over-current protection: Yes.

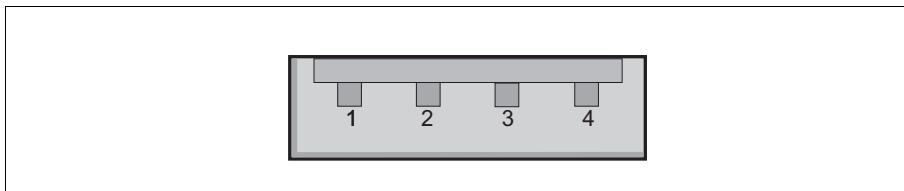

USB 3.1 connectors

The 4 USB 3.1 connectors on the back panel are standard rectangular, Series “A”, 9-pin receptacles. These connectors are backwards compatible with USB 3.0/2.0/1.1. The USB 3.1 interfaces run at 5 Gbps. The pinout of these USB 3.1 connectors is described in the USB Specification v3.0 from the USB Implementers Forum.

- Operating voltage and maximum current: 5 V, 900 mA.
- Over-current protection: Yes.

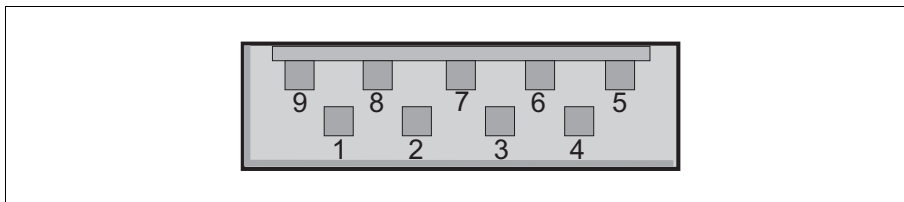

Gigabit Ethernet connectors

The 2 Gigabit Ethernet connectors are 8-pin, RJ45 connectors. The Ethernet connector on the left has an I210-IT interface and the Ethernet connector on the right has an I219-LM interface. The pinout of these connectors follows the 1000 BaseT Gigabit Ethernet standard found in the IEEE 802.3-2002 standard.

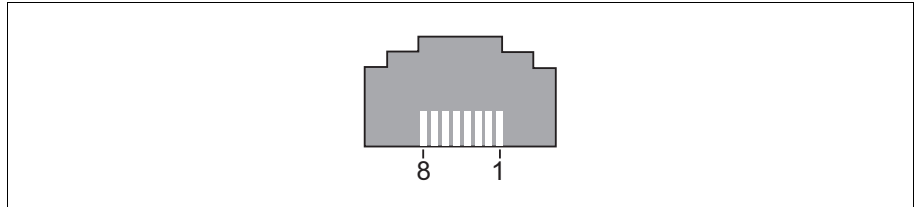

DisplayPort connector

The DisplayPort connector is a 20-pin female connector used to connect a display device such as a monitor. This connector supports DisplayPort specification version 1.2. The pinout for this connector is standardized by the Video Electronics Standards Association.

HDMI connector

The HDMI connector is a 19-pin female connector used to connect a high definition display device such as a monitor. This connector supports HDMI version 1.4. The pinout for this connector is standardized by the HDMI forum.

DVI-D video output connector

The DVI-D video output connector is a 29-pin female DVI connector, with pins 1 to 24 used for digital video output. The connector's pinout is outlined in the following table.

- Output voltage and maximum current: 5 V, 0.75 A.
- Auto-resettable fuse: Yes.

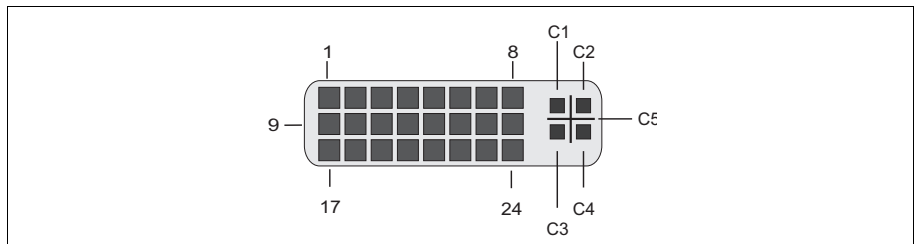

62 Appendix B: Technical reference

Pin	Signal	I/O	Description
1	TX2-	0	Transmission Data Line 2-.
2	TX2+	0	Transmission Data Line 2+.
3	GND	-	Ground.
4-5	NC	-	Not connected.
6	SCLK	I/O	DDC data clock line.
7	SDATA	I/O	DDC serial data line.
8	VSYNC	0	Vertical synchronization.
9	TX1-	0	Transmission Data Line 1-.
10	TX1+	0	Transmission Data Line 1+.
11	GND	-	Ground.
12-13	NC	-	Not connected.
14	+5V	0	+5 V _{dc}
15	GND	-	Ground.
16	HPD	I/O	Hot-plug detect.
17	TX0-	0	Transmission data line 0-.
18	TX0+	0	Transmission data line 0+.
19	GND	-	Ground.
20-21	NC	-	Not connected.
22	GND	-	Ground.
23	TXC+	0	Transmission data line Clock+.
24	TXC-	0	Transmission data line Clock-.
C1	NC	-	Not connected.
C2	NC	-	Not connected.
C3	NC	-	Not connected.
C4	NC	-	Not connected.
C5	NC	-	Not connected.

Analog video output (VGA) connector

The analog video output (VGA) connector is a high-density D-subminiature 15-pin, (HD-15¹) female connector. The pinout is outlined in the following table.

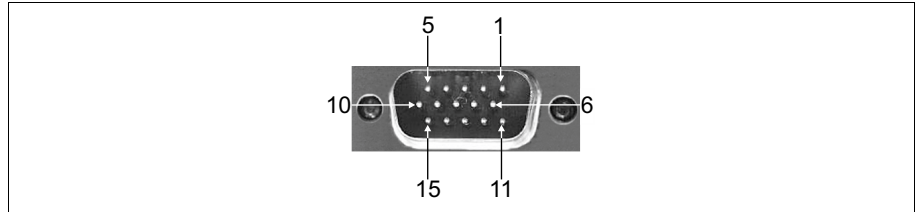

Pin	Signal	I/O	Description
1	RED	0	Red.
2	GREEN	0	Green.
3	BLUE	0	Blue.
4	NC	-	Not connected.
5-8	GND	-	Ground.
9	+5V	0	Power +5V; Includes an auto-resettable fuse. Maximum current: 5 V, 0.75 A.
10	GND	-	Ground.
11	NC	-	Not connected.
12	SDA	I/O	DDC serial data line.
13	HSYNC	0	Horizontal synchronization.
14	VSYNC	0	Vertical synchronization.
15	SCL	I/O	DDC data clock line.

1. Previously referred to as DBHD-15, but more accurately known as DE-15.

Serial port connector (COM port)

The serial port connector is a standard D-subminiature 9-pin (DB-9¹) male connector. Although the port is configured for the RS-232 standard by default, the configuration of the connector can be changed to accommodate either the RS-422 or RS-485 standard by adjusting the unit's UEFI setting; its pinout is outlined in the following table.

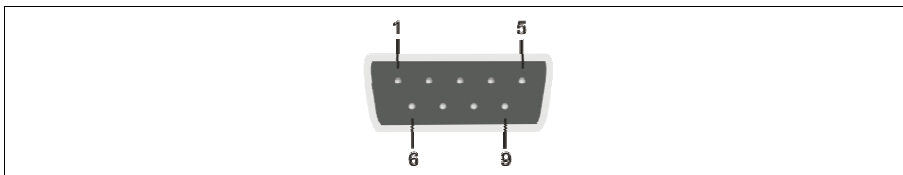

Pin	Hardware signal name	Description		
		RS-232 standard	RS-422 standard	RS-485 standard
1	Data Carrier detect.	DCD.	TX-.	RTX-.
2	Receive data.	RXD.	RX+.	N/A.
3	Transmit data.	TXD.	TX+.	RTX+.
4	Data terminal ready.	DTR.	RX-.	N/A.
5	Ground.	GND.	GND.	GND.
6	Data set ready.	DSR.	N/A.	N/A.
7	Request to send.	RTS.	N/A.	N/A.
8	Clear to send.	CTS.	N/A.	N/A.
9	No Power/5V/12V.	No Power/5V/12V.	N/A.	N/A.

1. More accurately known as DE-9.

Audio input, audio output, and microphone connectors

The audio input, audio output, and microphone connectors are 1/8" mini audio plugs. You can connect a stereo audio device to the audio input, audio output, or microphone connectors, respectively.

AC power connector

The Zebra 4Sight XV6 unit has an internal power supply. The power supply connector is a standard AC power connector, and the appropriate power cord is included with the Zebra 4Sight XV6 unit.



Descriptions of internal connectors

The diagrams in the following section will refer to the connector numbers as they appear in the diagram below. Inside the unit (on the motherboard) are the following connectors:

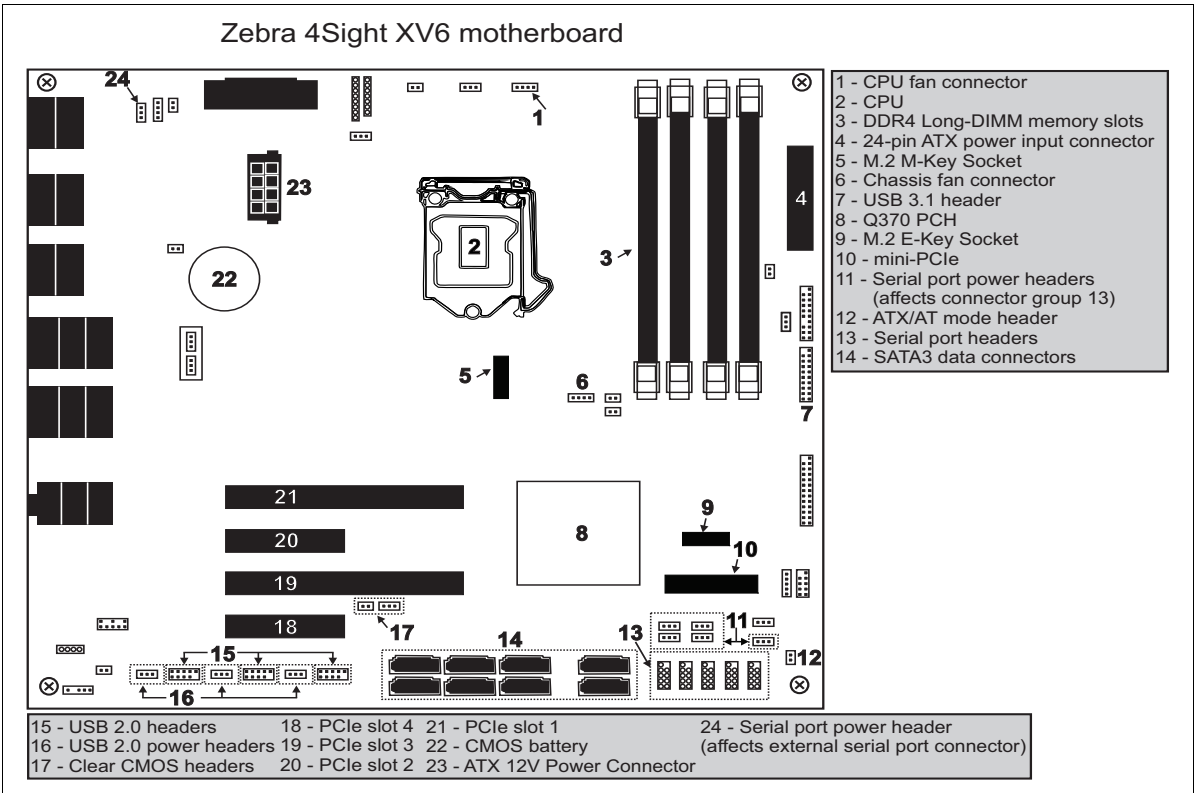

SATA3 data connectors for mass storage devices

The eight SATA3 data connectors are 7-pin, male connectors. They can be used for mass storage devices. SATA3 connector 1 is disabled when a drive is connected to the M.2 M-Key connector. The pinout for the SATA3 connectors is available at the website of the Serial ATA International Organization, <http://www.sata-io.org>.

Internal USB 2.0 headers

The three USB 2.0 headers are 9-pin male connectors. One header is already used by the USB 2.0 connectors on the exterior of the unit. Each USB 2.0 header supports two ports; you can use a custom adapter bracket with two USB 2.0 connectors to access these from the exterior of the unit.

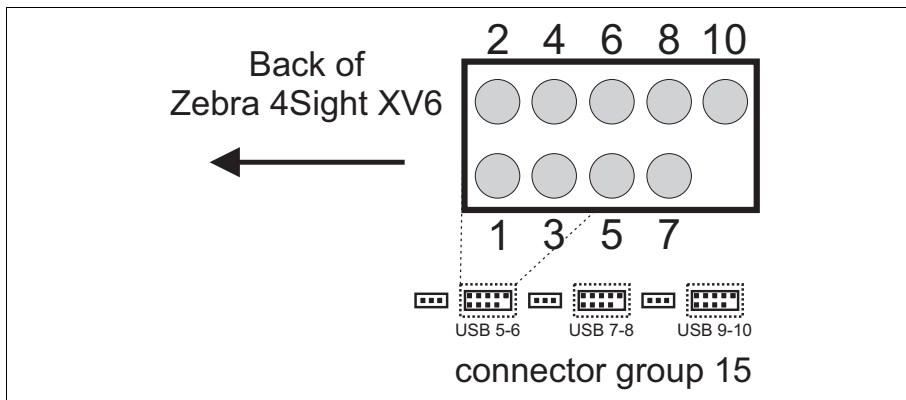

Pin	Signal
1	USB power
2	USB power
3	PA-
4	PB-
5	PA+
6	PB+
7	GND
8	GND
10	N/A

Internal USB 3.1 header

The single USB 3.1 header is a 19-pin male connector. The USB 3.1 header supports two ports; you can use a custom adapter bracket with two USB 3.1 connectors to access these from the exterior of the unit. The USB 3.1 interface runs at 5 Gbps.

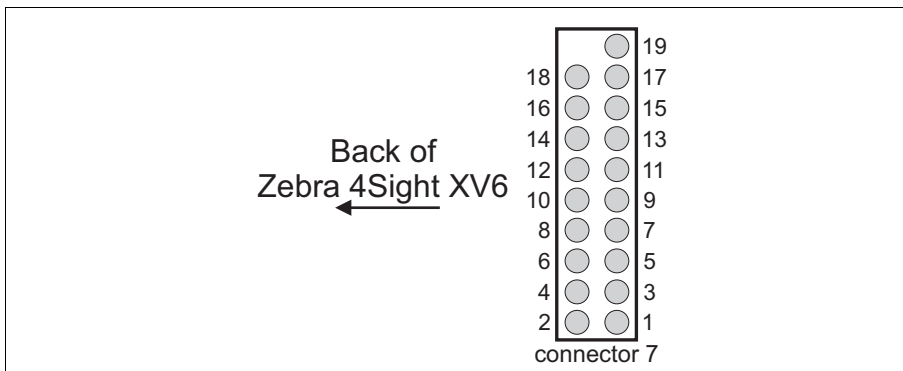

Pin	Signal
1	Dummy
2	IntA_PA_D+
3	IntA_PB_D+
4	IntA_PA_D-
5	IntA_PB_D-
6	GND
7	GND
8	IntA_PA_SSTX+
9	IntA_PB_SSTX+
10	IntA_PA_SSTX-
11	IntA_PB_SSTX-
12	GND
13	GND
14	IntA_PA_SSRX+
15	IntA_PB_SSRX+
16	IntA_PA_SSRX-
17	IntA_PB_SSRX-
18	Vbus
19	Vbus

Serial port headers

The five serial port headers are 9-pin male connectors. These connectors support the RS-232 standard. You can use a custom adapter bracket with a standard D-subminiature 9-pin (DB-9¹) connector to access these from the exterior of the unit. These connectors support the RS-232 standard.

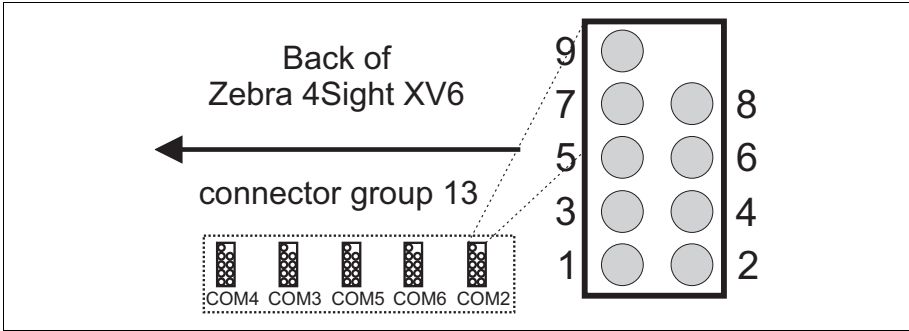

Pin	Signal
1	DDCD#
2	RRXD
3	TTXD
4	DDTR#
5	GND
6	DDSR#
7	RRTS#
8	CCTS#
9	+5V

1. More accurately known as DE-9.

Power supply connectors for peripheral devices (fans)

The two power supply connectors are 4-pin male connectors. One is connected to the CPU fansink, and the second is connected to the system fan.

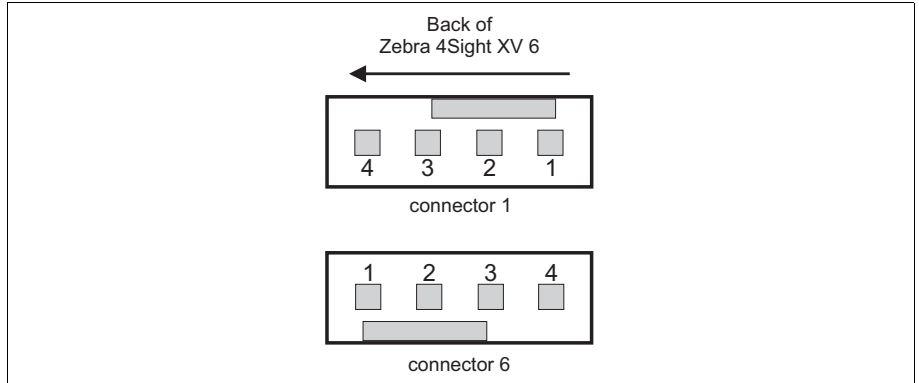

Pin	Description
1	Ground.
2	+ 12 V.
3	Indicates the speed of the fan (tachometer input).
4	Controls the speed of the fan, using pulse-width modulation (PWM).

Appendix C: Operating system recovery

This appendix provides instructions on how to restore or backup your operating system.

Zebra 4Sight XV6 Windows 10 IoT Enterprise configuration utility

Zebra 4Sight XV6 comes with the Windows 10 IoT Enterprise operating system pre-installed. To backup and restore Zebra 4Sight XV6, the Zebra 4Sight XV6 Rescue utility and the Zebra 4Sight XV6 Windows IoT Enterprise configuration utility (OSConfig) come pre-installed; these utilities allow you to:

- **Capture for deployment.** Creates a master image of your Zebra 4Sight XV6 unit's operating system partition so that you can deploy the unit's operating system, applications, and user settings, to multiple Zebra 4Sight XV6 units. The capture process creates a rescue USB key with a capture-for-deployment backup *.wim* file. When you deploy the image, Out-Of-Box-Experience customization steps are also performed, which assign a new unique ID to the new unit.
 - **OS backup.** Creates a backup image of your Zebra 4Sight XV6 unit's operating system partition and saves it to a USB key or specified drive. This process makes a backup (*.wim*) file similar to the capture-for-deployment backup, except it retains the unit's ID. This backup is only useful to restore the same unit from which the original backup was made, because it will also restore the unit's unique ID. When creating this type of backup, you have the option to simply save the backup file, or to create a rescue USB key (that is, to also configure the key with other files necessary for installing the backup image).
 - **Restore.** Reverts Zebra 4Sight XV6 to its factory default settings, restores an OS backup, or restores a capture-for-deployment backup.
- ❖ Note that the default mass storage device shipped with your Zebra 4Sight XV6 (M.2 SSD) has 4 partitions. The partitions are labeled as follows:
- RECOVERY. This partition is not assigned a drive letter.
 - OS. This partition is assigned to the C: drive.
 - SYSTEM. This partition is not assigned a drive letter.
 - MSR. This partition is not assigned a drive letter.

This appendix only deals with the RECOVERY and OS partitions.

The RECOVERY partition houses the Zebra 4Sight XV6 Rescue utility and factory image, and does not get reformatted if you restore an OS backup *.wim* file from the Zebra Rescue utility console. However, if you use a rescue USB key with a capture-for-deployment backup *.wim* file (*W10XV6.wim*), then both the RECOVERY and SYSTEM partitions are reformatted and restored to their original factory-configured state provided by Zebra.

To perform any of the backup, capture, or restore tasks, you must access your Zebra 4Sight XV6 directly since remote desktop is not available in the recovery environment. To access the unit directly, connect a display device, keyboard, and mouse to your Zebra 4Sight XV6. For information, refer to *Connecting peripheral devices* section, in *Chapter 2: Getting started with your Zebra 4Sight XV6 unit*.

For the latest information on backup, capture, and restore features, refer to the *OSreleasenotes.txt* file, found on the C: drive of your Zebra 4Sight XV6.

Microsoft Windows Out-Of-Box-Experience (OOBE)

When you start your Zebra 4Sight XV6 for the first time, Microsoft Windows performs its Out-Of-Box-Experience (OOBE) customization steps. The OOBE automatically performs initial customizations (such as setting the date and time), and creates a default user: ZUser and password: Zebra. The OOBE also generates a unique ID for your Zebra 4Sight XV6. At the end of your OOBE, a **Recommended actions** window pops up and prompts you to set your time zone. After you have set your time zone accordingly, ensure that User Account Control (UAC) is off, and optionally choose to create a restore USB. To find the **Recommended actions** window after completing the OOBE, open the OSConfig utility and go to the **Others** tab. For information on the OOBE default settings, refer to the *OSreleasenotes.txt* file on your Zebra 4Sight XV6 unit's C: drive.

If you backup your Zebra 4Sight XV6 with the OS backup option, the unique ID and initial OOBE customizations are saved inside the OS backup (*.wim* file); when you restore the OS backup, the unique ID is also restored. Be aware that if two units (or other devices) on the same network have the same ID, you will have issues. However, if you use the capture-for-deployment option to backup your Zebra 4Sight XV6, the ID and initial OOBE customizations are not saved; when you restore a captured backup on a Zebra 4Sight XV6 unit, Windows will perform its OOBE and generate a new unique ID and initial OOBE customizations for the unit.

Capturing the Zebra 4Sight XV6 operating system partition for deployment

You can capture an image of your Zebra 4Sight XV6's operating system partition (the operating system, application, and some settings) and then deploy it on multiple Zebra 4Sight XV6 units. The capture-for-deployment process will save the image to a capture-for-deployment backup *.wim* file, while also creating a rescue USB key so that you can deploy the capture to other Zebra 4Sight XV6 units. The capture-for-deployment backup *.wim* file does not contain the user settings and unique ID of the original unit. When you deploy the capture to the target units and reboot them, Microsoft Windows OOBE will assign them their own unique ID and allow you to configure their user settings.

To capture an image of your Zebra 4Sight XV6 unit's operating system partition, you must access your Zebra 4Sight XV6 directly; you cannot perform this task remotely. To access the unit directly, connect a display device, keyboard, and mouse to your Zebra 4Sight XV6. For information, refer to *Connecting peripheral devices* section, in *Chapter 2: Getting started with your Zebra 4Sight XV6 unit* for more information.

To make a capture-for-deployment backup of your Zebra 4Sight XV6, perform the following steps directly on your Zebra 4Sight XV6:

1. From the Windows **Start** menu, launch the OSConfig utility. Disable the Unified Write Filter (UWF) (if it is on), so that you can write to the drive. This option is found on the **Write Filter** tab of the **OSConfig** dialog.
 2. Configure your Zebra 4Sight XV6 unit to your required specifications and ensure that you do not need to make any more changes.
 3. Open the OSConfig utility from the Windows **Start** menu and select the **Capture OS** tab; then, click on the **Reboot to Audit Mode** button. Your Zebra 4Sight XV6 will reboot in audit mode (administrative mode).
 4. When the reboot process completes, the **System preparation tool** dialog opens. Click on the **Cancel** button to close this dialog.
- ❖ Note that, when you boot in audit mode, the **System preparation tool** dialog opens every time. You can close or ignore this dialog.

5. Now, in audit mode (administrative mode), open the OSConfig utility and select the **Capture OS** tab; then, click on the **Reboot and launch capture tool** button.
6. When the reboot process completes, a list of possible options are displayed. Click on the **Troubleshoot** option and then on the **Zebra Rescue Utility** option.
7. When the **Zebra Rescue Utility** dialog opens, you must read the license agreement. When done, click on the **I agree** button to accept the license agreement.
8. The next page is presented, with an option already selected: **Capture the OS for deployment**; leave this option as is. Below this, you can specify the location of your USB key. Ensure your USB key has a minimum of 16 Gbytes. If you do not already have your USB key connected, you can do so now. Once you have selected the location of the USB key, you can click OK and the process will begin.

WARNING!

This will reformat your USB key and all data will be erased.

The Zebra 4Sight XV6 Rescue utility configures the USB key to be a rescue USB key with all the necessary settings to restore your capture-for-deployment backup *.wim* file onto other Zebra 4Sight XV6 units.

9. When the process completes, a message dialog opens, explaining what was done. Click on the **OK** button to perform a shut down and reboot of Windows 10 IoT Enterprise.

To use the configured USB key to restore the operating system partition of your Zebra 4Sight XV6, or to configure another Zebra 4Sight XV6, refer to the *Restore Windows 10 IoT Enterprise* section, later in this appendix.

OS backup of Zebra 4Sight XV6 Windows 10 IoT Enterprise

You can create an OS backup *.wim* file of your Zebra 4Sight XV6 unit's operating system partition and save the file to a specified location. It is useful to do this procedure if you need to save any changes made to the specific Zebra 4Sight XV6 unit. Note that the OS backup process will copy the unique ID of the unit. This ID will be applied to any Zebra 4Sight XV6 that is restored with this backup *.wim* file; therefore, an OS backup should only be applied to the same unit from which it was taken. If two units with the same unique ID are running on the same network, there will be network conflicts. Be aware of this limitation when performing an OS backup.

To perform an OS backup, you must access your Zebra 4Sight XV6 directly; you cannot perform this task remotely. To access the unit directly, connect a display device, keyboard, and mouse to your Zebra 4Sight XV6. For information, refer to *Connecting peripheral devices* subsection of the *Connecting peripheral devices* section, in *Chapter 2: Getting started with your Zebra 4Sight XV6 unit* for more information.

To backup your operating system partition, perform the following directly from your Zebra 4Sight XV6:

1. Save all your work and close all running applications.
2. From the Windows **Start** menu, launch the OSConfig utility.
3. Go to the **Write Filter** tab. If the Unified Write Filter (UWF) option is enabled, disable it.
4. Click on the **Capture OS** tab.
5. On the **Capture OS** tab, click on the **Reboot and launch backup tool** button that is found in the **Backup for this unit** area. Your Zebra 4Sight XV6 will reboot.
6. When the reboot process completes, it will display a screen asking you to choose an option. Click on the **Troubleshoot** option, and then on the **Zebra Rescue Utility** option.

7. When the **Zebra Rescue Utility** dialog opens, you must read the license agreement. When done, click on the **I agree** button to accept the license agreement.
8. The next page is presented with an option already selected: **Backup the OS for this unit**; leave this option as is. Below this, you can specify the location of your USB key. If you do not already have your USB key connected, you can do so now. It is not recommended to save the backup in the current operating system partition, or to a virtual drive. It is recommended to save to a USB key with at least 16 Gbytes free. Once you have selected the location of the USB key, click on **OK** and the Zebra Rescue utility will copy the information to the destination specified.
9. When the process completes, a message dialog will open, explaining what was done. Click on the **OK** button.
10. After the reboot, if UWF was enabled before you started the OS backup process, launch the OSConfig utility from the Windows **Start** menu, and re-enable UWF.
 - ❖ Note that to restore the OS backup without a working copy of the operating system on your Zebra 4Sight XV6, additional files are required. The OS backup *.wim* file can either be used with the Zebra 4Sight XV6 Rescue utility, if the RECOVERY partition is not corrupt, or with a rescue USB key, if the RECOVERY partition is corrupt. To restore your Zebra 4Sight XV6 with the Zebra 4Sight XV6 Rescue utility, refer to the *Restore Windows 10 IoT Enterprise* section. To create a rescue USB key, refer to the section *Making a rescue USB key for Windows 10 IoT Enterprise* section.

Making a rescue USB key for Windows 10 IoT Enterprise

In the case that your Zebra 4Sight XV6 operating system partition becomes corrupt, the easiest way to restore your unit is to use a rescue USB key containing the Zebra Rescue utility and a backup of your operating system partition. This procedure requires a USB key with at least 16 Gbytes.

To create a rescue USB key, you must access your Zebra 4Sight XV6 directly; you cannot perform this task remotely. To access the unit directly, connect a display device, keyboard, and mouse to your Zebra 4Sight XV6. For information, refer to *Connecting peripheral devices* section, in *Chapter 2: Getting started with your Zebra 4Sight XV6 unit* for more information.

When creating a rescue USB key, you must already have a backup file that you want to use for the recovery. This could either be the Zebra default factory settings backup *.wim* file (*W10Ex64XV6.wim*, *W10Ex64XV6DA.wim*, or *W10Ex64XV6DL.wim*) that comes in your recovery partition, or an OS backup file that you have created (*W10XV6.wim*) using the procedure in the *OS backup of Zebra 4Sight XV6 Windows 10 IoT Enterprise* section earlier in this chapter.

To create a rescue USB key of your operating system partition, perform the following:

1. From the **Windows Start** menu, select **Settings**. From the presented window, select **Update & Security** and then **Recovery**. Under **Advanced Startup**, select **Restart now**. This will restart your Zebra 4Sight XV6 and then display the Zebra Rescue utility.
2. When the reboot process completes, it will display a screen asking you to choose an option. Click on the **Troubleshoot** option, and then on the **Zebra Rescue Utility** option.
 - ❖ If you do not have access to Zebra Rescue utility, contact Zebra support.
3. When the **Zebra Rescue Utility** dialog opens, you must read the license agreement. When done, click on the **I agree** button to accept the license agreement.
4. In the following dialog, select **Create USB drive for factory restore**.

5. Insert a USB key into your USB drive. If using a backup file that you have previously made and stored on a USB key, you will need to insert a second USB key with that backup.
6. The Zebra ResQDisk utility will open. In the **Select OS image** area, select to use the factory image or browse to the location where your required OS backup *.wim* file is found and use that file. In the **Select USB storage device location** area, select the USB drive that will be reformatted to a bootable USB drive.

WARNING!

- ❖ Note that this will reformat your USB key and all its data will be erased.
7. Select **Go** and the process of making a bootable USB drive will begin. When this operation completes successfully, your rescue USB key can then be used to either deploy a capture-for-deployment backup, restore an OS backup, or recover the operating system of your Zebra 4Sight XV6 unit to factory settings, depending on the *.wim* file that you used to make the bootable USB.

Restore Windows 10 IoT Enterprise

You can restore the Windows 10 IoT Enterprise operating system partition of your Zebra 4Sight XV6 unit, using the Zebra 4Sight XV6 Rescue utility with an OS backup *.wim* file or a capture-for-deployment backup *.wim* file.

Warning!

The restore operation will reformat and erase all data currently on the Zebra 4Sight XV6 storage drive (SSD). If you have two (or more) partitions on your Zebra 4Sight XV6 storage drive, or have external drives connected, select the correct drive or disconnect from all external hard drives to prevent data being erased by accident.

- ❖ The RECOVERY partition houses the Zebra 4Sight XV6 Rescue utility and does not get reformatted if you restore an OS backup *.wim* file from the Zebra Rescue utility console. However, if you use a rescue USB key with a capture-for-deployment backup *.wim* file (*W10XV6.wim*), or restore to factory default settings file (*W10Ex64XV6.wim*, *W10Ex64XV6DA.wim*, or *W10Ex64XV6DL.wim*), then both the RECOVERY and OS partitions are reformatted.

To perform any of the backup, capture, or restore tasks, you must access your Zebra 4Sight XV6 directly since remote desktop is not available in the recovery environment. To access the unit directly, connect a display device, keyboard, and mouse to your Zebra 4Sight XV6. For information, refer to *Connecting peripheral devices* section, in *Chapter 2: Getting started with your Zebra 4Sight XV6 unit* for more information.

To restore your Zebra 4Sight XV6 unit's operating system partition, perform the following:

1. From the **Windows Start** menu, select **Settings**. From the presented window, select **Update & Security** and then **Recovery**. Under **Advanced Startup**, select **Restart now**. This will restart your Zebra 4Sight XV6 and then display the Zebra Rescue utility.
2. When the reboot process completes, it will display a screen asking you to choose an option. Select **Zebra 4Sight XV6 - Restore OS**.
3. Select which *.wim* file (*W10XV6.wim*) to restore.
 - ❖ Note that these files are created with the OS backup or capture-for-deployment backup options, described earlier in this chapter.
4. Follow all on-screen instructions.

Appendix D: Listing of Zebra 4Sight XV6 imaging computers

This appendix lists the key feature changes for specific versions and revisions of the Zebra 4Sight XV6 imaging computers.

Key feature changes

Part number	Version	Description
XV6I5M16, XV6I5M16DA, XV6I5M16DA+	1	First shipment of Zebra 4Sight XV6.
XV6I5M32CT	1	First shipment of Zebra 4Sight XV6 for deep learning training.

