

Load the Ribbon



Note • This section applies only to printers that have the Thermal Transfer option installed.

Ribbon is used only with thermal transfer labels. For direct thermal labels, do not load ribbon in the printer. To determine if ribbon must be used with a particular media, see [When to Use Ribbon](#) on page 18.

Caution • While performing any tasks near an open printhead, remove all rings, watches, hanging necklaces, identification badges, or other metallic objects that could touch the printhead. You are not required to turn off the printer power when working near an open printhead, but Zebra recommends it as a precaution. If you turn off the power, you will lose all temporary settings, such as label formats, and you must reload them before you resume printing.



Important • Use ribbon that is wider than the media to protect the printhead from wear. Ribbon must be coated on the outside.

To load ribbon, complete these steps:

1. Raise the media door.

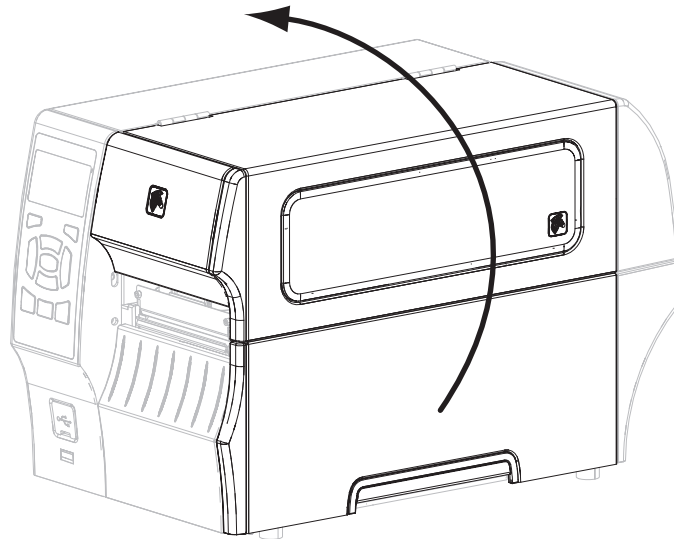



2. **Caution** • The printhead may be hot and could cause severe burns. Allow the printhead to cool.

Open the printhead assembly by rotating the printhead-open lever.

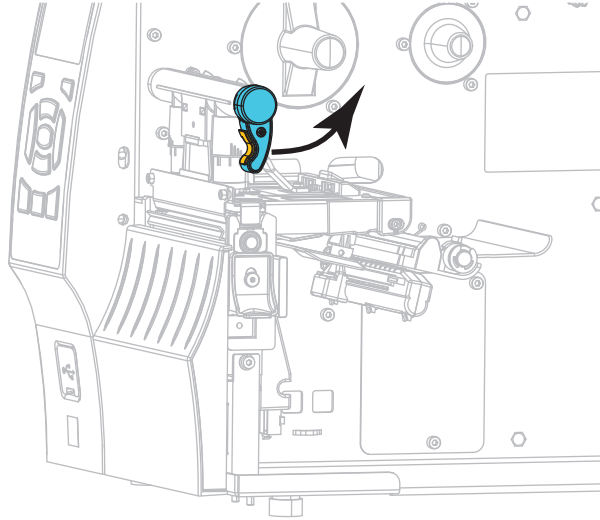

3. Place the roll of ribbon on the ribbon supply spindle with the loose end of the ribbon unrolling as shown. Push the roll back as far as it will go.

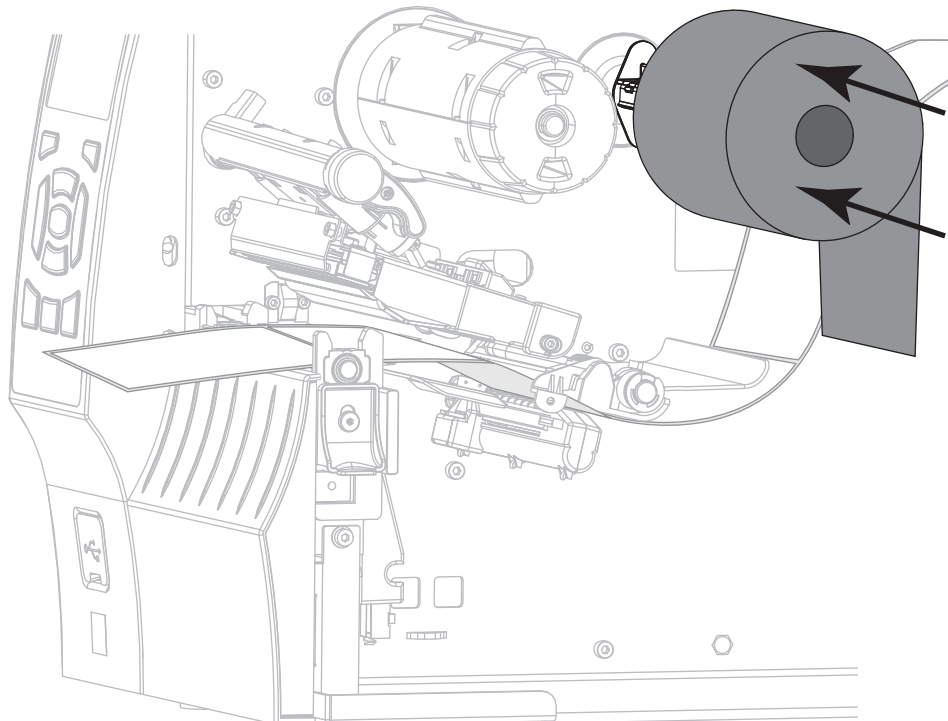

4. Bring the ribbon under the printhead assembly, and then wrap it several turns around the ribbon take-up spindle.

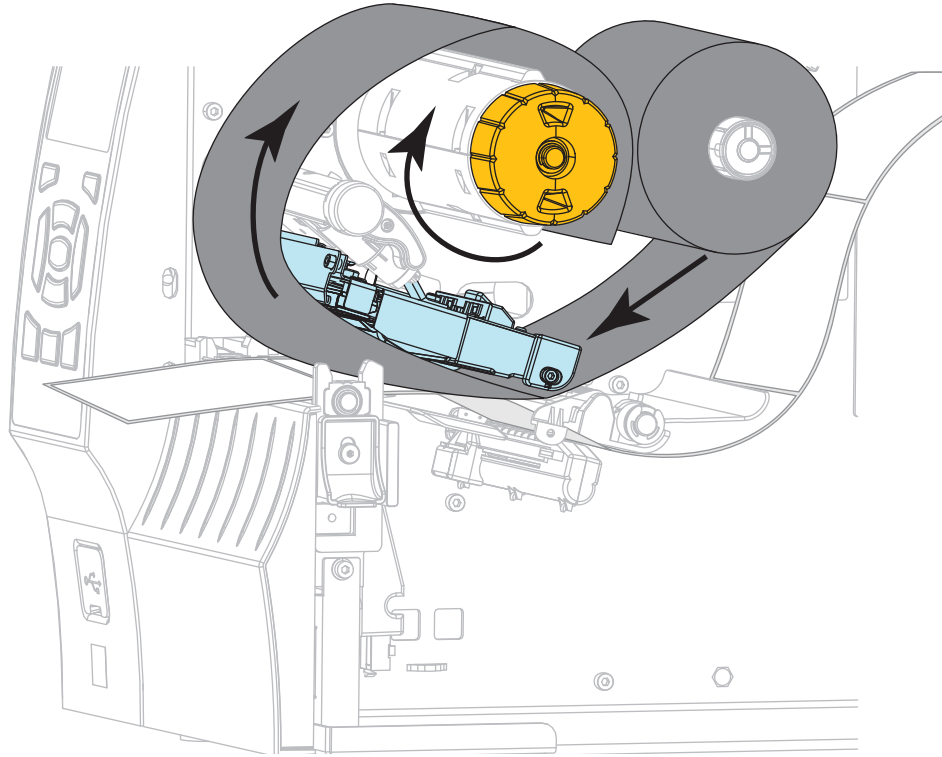

5. Is media already loaded in the printer?

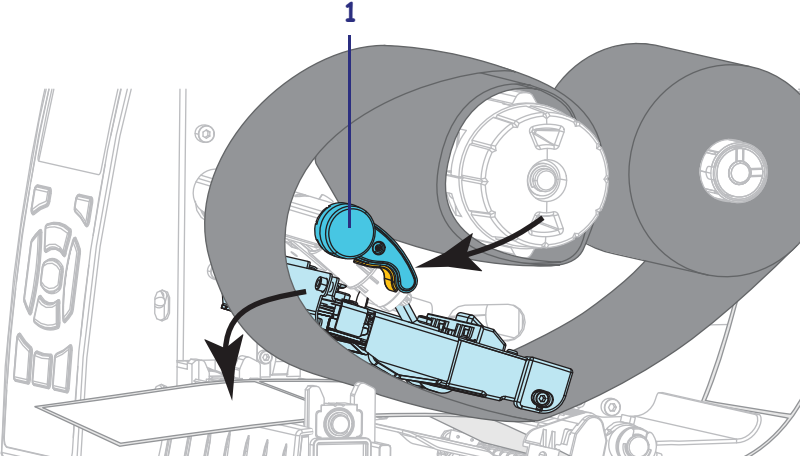
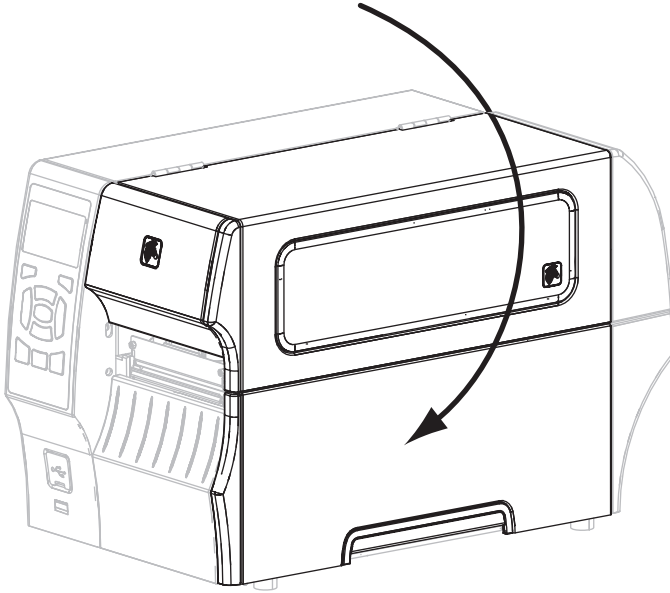
If...	Then...
No	Continue with step 3 on page 35 to load media in the printer.
Yes	<p data-bbox="626 373 1373 436">a. Rotate the printhead-open lever (1) downward until it locks the printhead in place.</p>  <p data-bbox="626 919 911 951">b. Close the media door.</p>  <p data-bbox="626 1591 1170 1623">c. If necessary, press PAUSE to enable printing.</p>

Ribbon Overview

Ribbon is a thin film that is coated on one side with wax, resin, or wax resin, which is transferred to the media during the thermal transfer process. The media determines whether you need to use ribbon and how wide the ribbon must be.

When ribbon is used, it must be as wide as or wider than the media being used. If the ribbon is narrower than the media, areas of the printhead are unprotected and subject to premature wear.

When to Use Ribbon

Thermal transfer media requires ribbon for printing while direct thermal media does not. To determine if ribbon must be used with a particular media, perform a media scratch test.

To perform a media scratch test, complete these steps:

1. Scratch the print surface of the media rapidly with your fingernail.
2. Did a black mark appear on the media?

If a black mark...	Then the media is...
Does not appear on the media	Thermal transfer. A ribbon is required.
Appears on the media	Direct thermal. No ribbon is required.

Coated Side of Ribbon

Ribbon can be wound with the coated side on the inside or outside (Figure 5). This printer can only use ribbon that is coated on the outside. If you are unsure which side of a particular roll of ribbon is coated, perform an adhesive test or a ribbon scratch test to determine which side is coated.

Figure 5 • Ribbon Coated on Outside or Inside

