

Introduction

This guide provides instruction on how to install the VC Remote Keyboard for the VC80 and VC70 Vehicle Computers (VC).

The keyboard features include:

- Backlight Adjustment
- Caps Lock
- IP 66 Sealing
- Replaceable Elastomer
- Keyboard Heater for Condensing Environments
- Wide Temperature Range (-30° C to 50° C)

For detailed VC information, refer to the VC80 User Guide and VC70 User Guide located at: www.zebra.com/support.

Required Tools

- T10 screwdriver for cable and cable cover installation
- T20 screwdriver for the keyboard on the tray and RAM plate
- T25 screwdriver for mounting the arms on the VC80 and VC70 terminal

Installing Keyboard Cable

To install the keyboard cable:

1. Turn the connector on the cable at a right angle as shown below and insert the connector (with connector clips on top) into the keyboard housing.

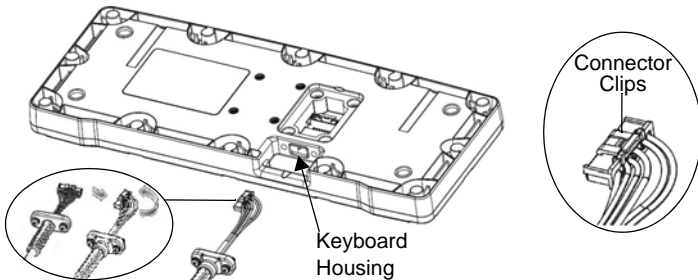

2. Turn the connector on the cable straight (with connector clips on top) and plug the connector in the keyboard.

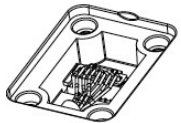

3. Mount the cable retention on the housing and screw the two retention screws. Torque the M3 screw to 6kgf-cm (5.2 lbs-in).

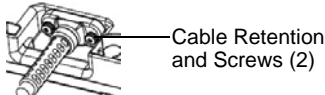

4. Gently push the wires downward and install the cable cover. Torque the four M3 screws to 6kgf-cm (5.2 lbs-in).

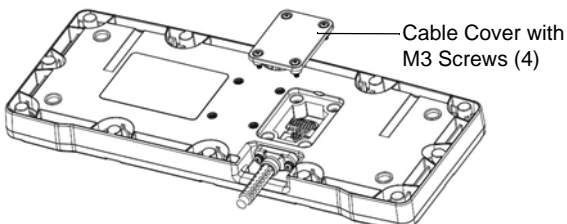

Installing Keyboard on VC80

To install the keyboard on the VC80 with a keyboard tray:

1. Position the keyboard on the tray and fasten four M4x10mm screws. Torque the screws to 8.0 kgf-cm (7.0 lbs-in).

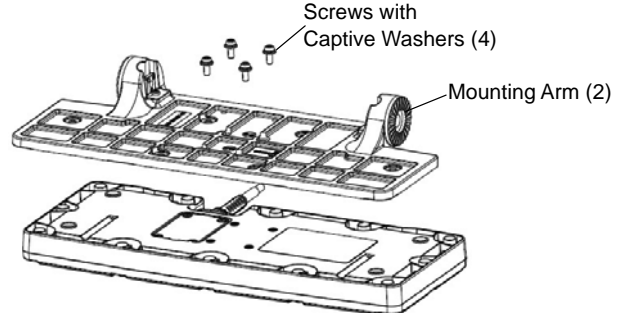

2. Insert the keyboard locking knobs through the washers and brackets and screw into the keyboard tray. Tighten slightly but not fully.

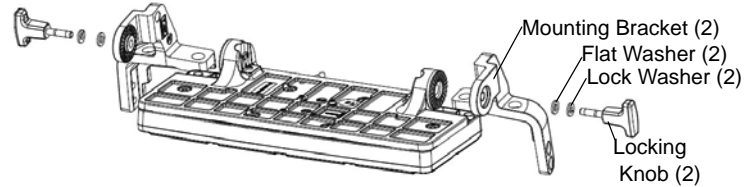

3. Attach the mounting arms to both sides of the VC80, using the M5x14mm Torx head screws with flat and lock washers. Torque the mounting arms Torx head screws to 40 + 10% kgf-cm (35 + 10% lbs-in).

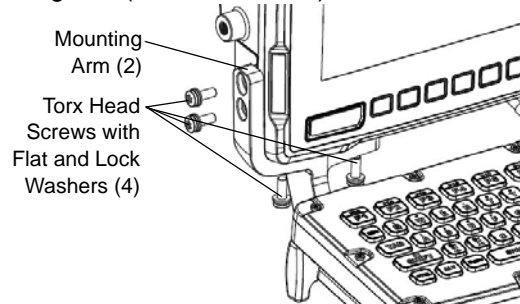

4. To adjust the keyboard tray position, loosen the right and left locking knobs two full turns. Rotate the keyboard tray to the desired position and tighten the keyboard tray locking knobs to secure the tray in position.



5. Plug the keyboard cable into the Powered USB connector and secure the cable in the cable retainer.

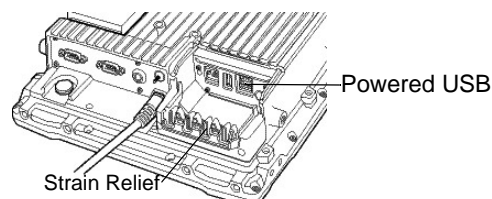

Installing Keyboard on VC70

To install the keyboard on the VC70 with a keyboard tray:

1. Position the keyboard on the tray and fasten four M4x10mm screws. Torque the screws to 8.0 kgf-cm (7.0 lbs-in).

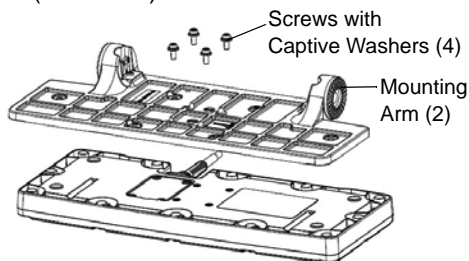

2. Attach the left and right mounting arms to both sides of the VC70, using the M5x14mm Torx head screws with flat and lock washers. Only tighten the cap screws three turns.

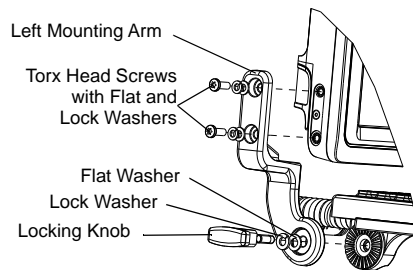

3. Insert the keyboard locking knobs through the washers and brackets and screw into the keyboard tray. Tighten fully to lock into place.
4. Torque the mounting arms Torx head screws to 40 + 10% kgf-cm (35 + 10% lbs-in).
5. To adjust the keyboard tray position, loosen the right and left locking knobs two full turns and rotate the keyboard tray to the desired position.
6. Tighten the keyboard tray locking knobs to secure the tray in position.

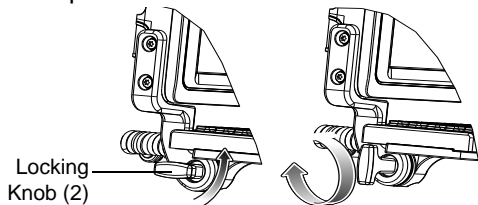

7. Plug in the keyboard cable in one of the following manners:
 - For a Freezer configuration, plug the Y-cable into the USB-2 connector and the COM 1 connector to draw more power for the keyboard heaters. Ensure that the output power on COM 1 is On.
 - For a Non-Freezer configuration, plug the standard cable into the USB-2 connector, and screw in the locking screws using a flat head screw driver.

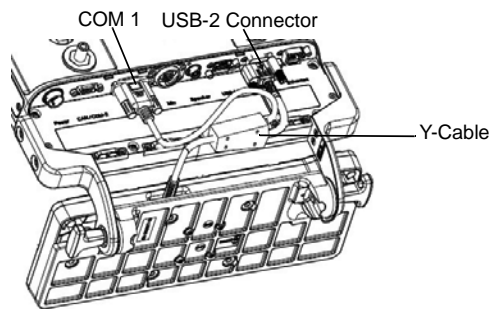

✓ **NOTE** On some legacy VC70 devices that are not fully compliant with USB HID Keyboard specifications, the orange function keys are not supported for F13 to F24. Use the following combinations:

- For F13 - F20, press **Shift - F3 ~ Shift - F10**
- For F21 - F24, press **Ctrl - F1 ~ Ctrl - F4**

Installing Keyboard on RAM Mount



CAUTION If mounting to a thin surface such as drywall or plywood, a reinforcing plate is required.

Use RAM Mounts if the keyboard is not attached to the VC, but mounted remotely from the VC at another place on the truck.

RAM Parts

Part Number	Description
MT3502	2.25" Ball base
M4x14	Four Screws with Captive Washers

To mount the RAM mount on the keyboard, align the four holes on the ball base plate with the four holes on the keyboard bottom, and secure using the four screws with captive washers.

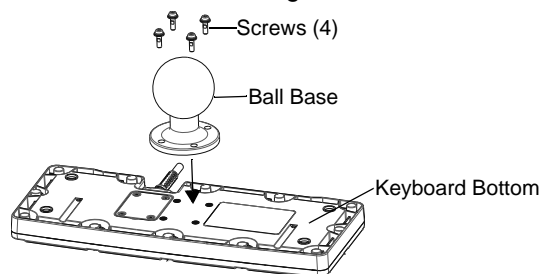

Keyboard Heater

The keyboard contains three internal USB heaters that prevent damage when operating in condensing environments:

- **Low** - this heater operates with VC80 and VC70 standard cables and the VC70 Y-cable, and turns on when the temperature is below 20° C.
- **Normal** - this heater operates with the VC80 standard cable and VC70 Y-cable, and turns on when the temperature is below 15° C.
- **High** - this heater operates with the VC80 standard cable and VC70 Y-cable, and turns on when the temperature is below 5° C.

Zebra Technologies Corporation, Inc.
3 Overlook Point
Lincolnshire, IL 60069, U.S.A.
<http://www.zebra.com>

Zebra and the stylized Zebra head are trademarks of ZIH Corp., registered in many jurisdictions worldwide. All other trademarks are the property of their respective owners.

©2017 ZIH Corp and/or its affiliates. All rights reserved.



MN-002967-01 Rev A June 2017