

Installation Instruction for ST605I Forklift Holster

WARNING: Failure to install the mount correctly or modifications to the mount may result in serious injury or damage to property. Contact Psion Technical Support or your Psion representative if you have problems installing this mount. To ensure operator safety, you must use a calibrated torque wrench and the supplied mounting hardware when fastening the cradle and mount. Use of this mount in vehicles driven on public roads or highways is prohibited. Contact Psion for further details.

The following restrictions must be strictly enforced:

- Do not use the forklift holster as a hand-hold. Using the holster in this manner may cause the person to fall and/or dislodge the handheld terminal.
- Do not add weight or attach any other items to the forklift holster. Additional elements may fall causing injury or may increase chance of failure and/or damage in mounting hardware and/or mounts.

Forklift holsters used in industrial or vibration generating environments may be subjected to fatigue, stress and/or part wear. A periodic inspection of the mounting hardware and strap should be performed to ensure parts are retightened as needed, free of fractures, excessive wear and/or other environmental damage. Any forklift holsters found to be unsafe should be removed and the replaced immediately.

Installation

1. The forklift holster can be installed in a variety of orientations (See Figure 1 and 2). Select the best orientation for your specific application.

Figure 1

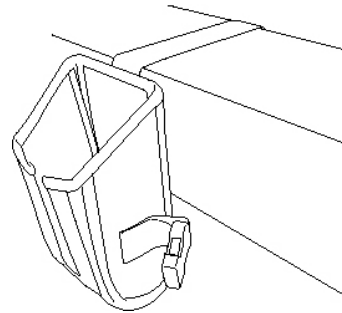
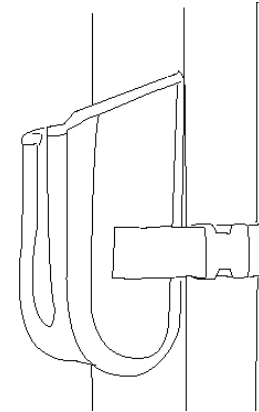
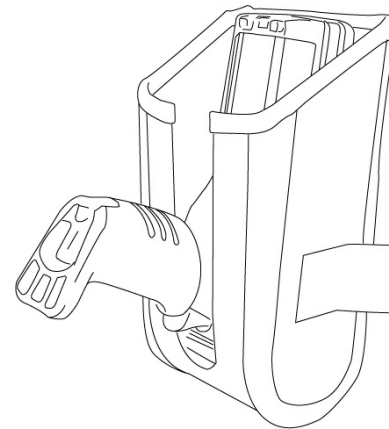

Figure 2



2. Insert the handheld terminal scanner end down in the forklift holster to ensure the most secure carrying position. (See Figure 3).

Figure 3



Appendix A: Support Services

For technical support, please visit the Support section of our community Ingenuity Working:
<http://community.pSION.com/support>