

8 7 6 5 4 3 2 1

SEE MATROX SPEC No SM027 FOR COSMETIC STANDARDS
SEE MATROX SPEC No SM003 FOR MORE INFORMATION

REVISIONS					
REV.	DESCRIPTION	D.O.	CHECKED BY	APPROVED	DATE
P-5	PRELIMINARY	AB	G. BLAIS		08/01/2023

$\varnothing 2.50 \mp 4.50$
M3X0.5 - 6H ∓ 4.50
 $\sphericalangle \varnothing 3.50 \times 90.00^\circ$, NEAR SIDE

8X $\varnothing 3.30 \mp 5.50$
M4X0.7 - 6H ∓ 4.00
 $\sphericalangle \varnothing 4.50 \times 90.00^\circ$, NEAR SIDE

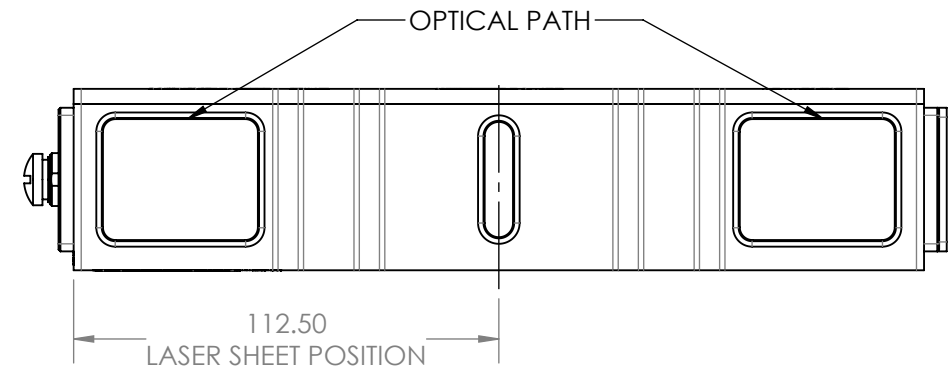
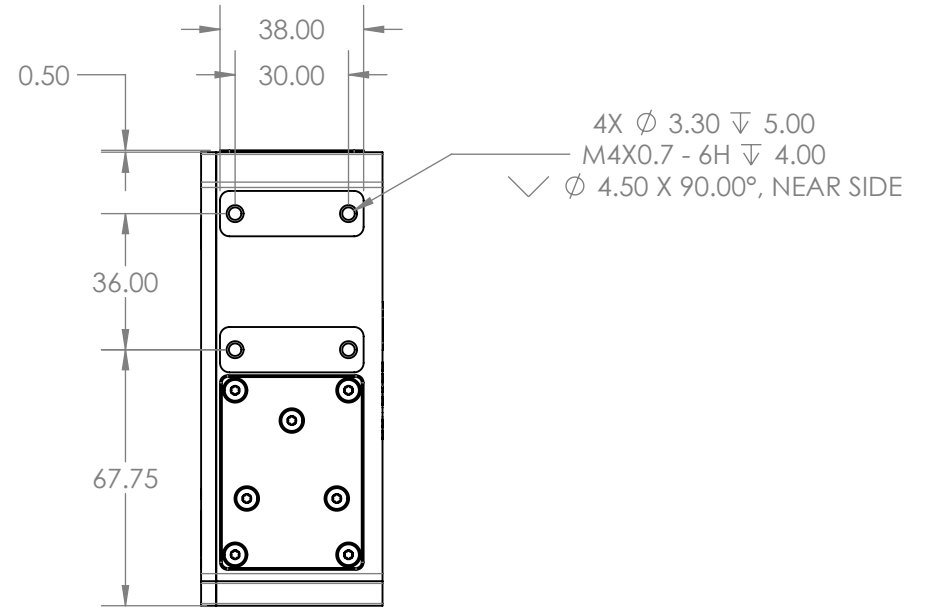
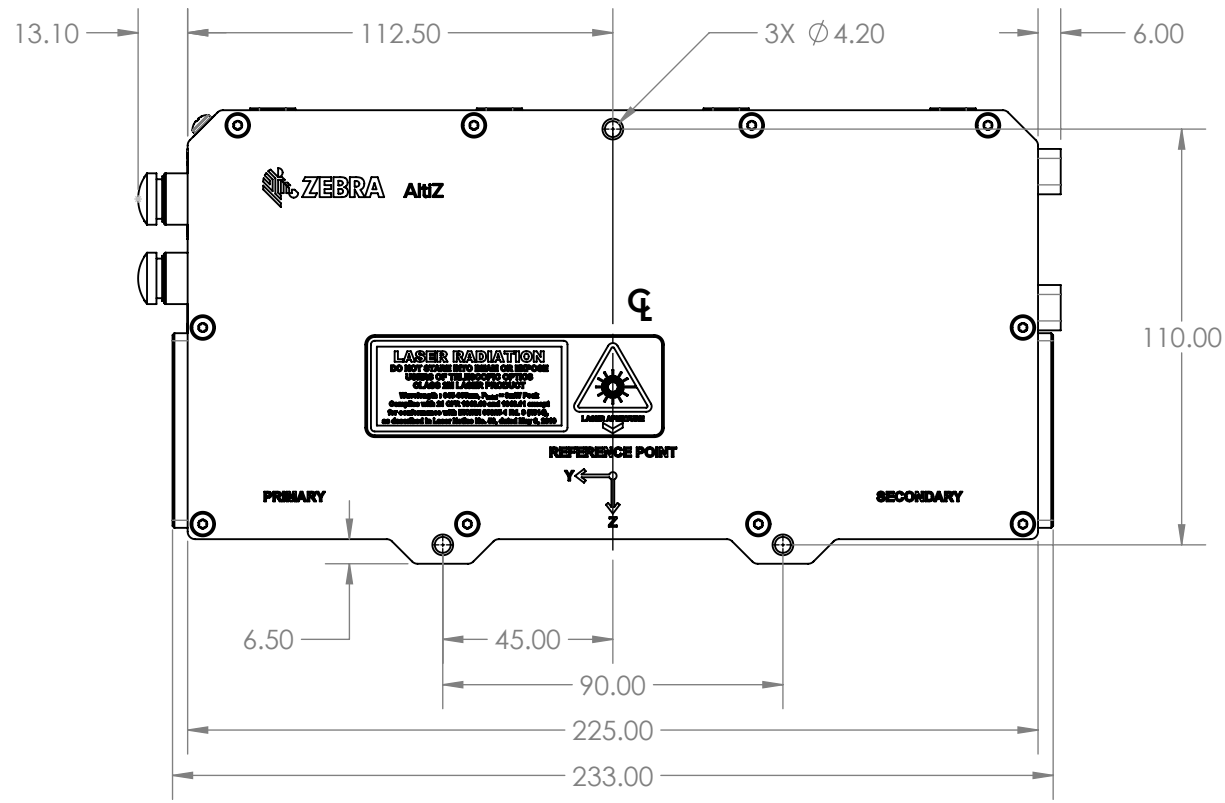
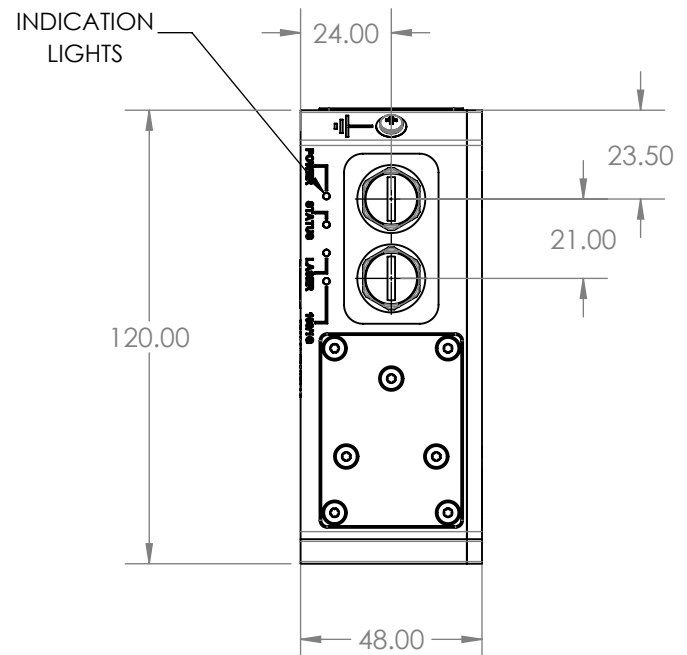
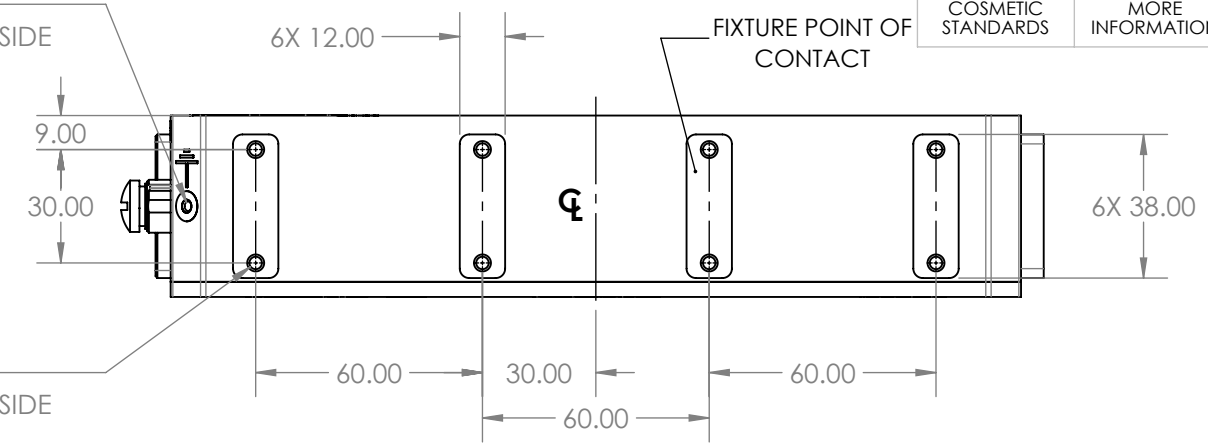

QUANTITY	ITEM	DESCRIPTION	MANUFACTURERS / PART No	NOTES
TOLERANCES UNLESS OTHERWISE SPECIFIED		GROUP	THIRD ANGLE PROJECTION	
DIMENSIONS ARE IN : MILLIMETERS <input checked="" type="checkbox"/> INCHES <input type="checkbox"/>		IMAGING		
.X	.XX	.XXX	PROJECT	3D Profiler
$\pm .3$	$\pm .07$	$\pm .050$	FILENAME	TLA_5.SLRDRW
BREAK SHARPS EDGE		BENDS	DRAWN BY	A. BERGERON
0.38		0.79R	CHECKED BY	G. BLAIS
MATERIAL		SIZE	DATE	August, 2023
FINISH		SCALE	1:2	
			TITLE	Zebra Altiz (Top Level Assy.)
			0000-00	
			DRAWING NO.	0000-05-00
			REV	P-5
			SHEET 1 OF 4	

8 7 6 5 4 3 2 1

8 7 6 5 4 3 2 1

REVISIONS					
REV.	DESCRIPTION	D.O.	CHECKED BY	APPROVED	DATE
P-5	PRELIMINARY	AB	G. BLAIS		08/01/2023

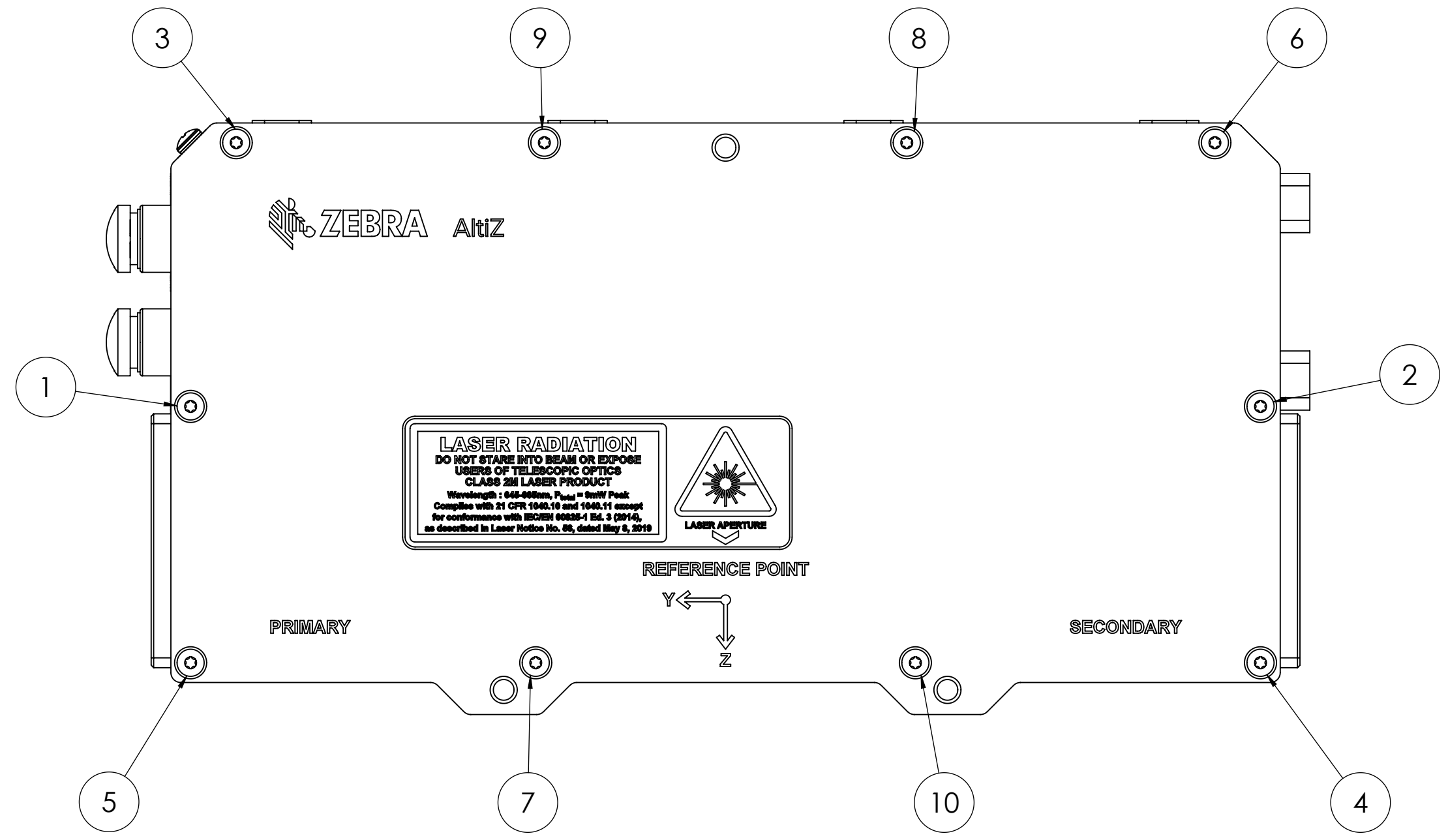

D
C
B
A

D
C
B
A

8 7 6 5 4 3 2 1

QUANTITY	ITEM	DESCRIPTION	MANUFACTURERS / PART No	NOTES
TOLERANCES UNLESS OTHERWISE SPECIFIED		GROUP	THIRD ANGLE PROJECTION	
DIMENSIONS ARE IN : MILLIMETERS <input checked="" type="checkbox"/> INCHES <input type="checkbox"/>		IMAGING		
.X	.XX	.XXX	ANGLES	HOLES DIA.
± .3	± .07	± .050	± 0.5°	± .18 ± .00
BREAK SHARPS EDGE		BENDS		
0.38		0.79R		
MATERIAL		DRAWN BY		matrox 1055 ST-REGIS DORVAL, QUEBEC H9P-2T4 THE INFORMATION CONTAINED IN THIS DRAWING IS THE SOLE PROPERTY OF MATROX. ANY REPRODUCTION IN PART OR AS A WHOLE WITHOUT THE WRITTEN PERMISSION OF MATROX IS PROHIBITED.
		A. BERGERON		
		CHECKED BY		
		G. BLAIS		
FINISH		SIZE	DATE	TITLE
		B	August, 2023	Zebra Altiz (Top Level Assy.) 0000-00
		SCALE	1:1	DRAWING NO.
				0000-05-00
				REV
				P-5
				SHEET
				2 OF 4

8 7 6 5 4 3 2 1

SEE MATROX SPEC No SM027 FOR COSMETIC STANDARDS	SEE MATROX SPEC No SM003 FOR MORE INFORMATION	REVISIONS					
		REV.	DESCRIPTION	D.O.	CHECKED BY	APPROVED	DATE
		P-5	PRELIMINARY	AB	G. BLAIS		08/01/2023

D
C
B
A

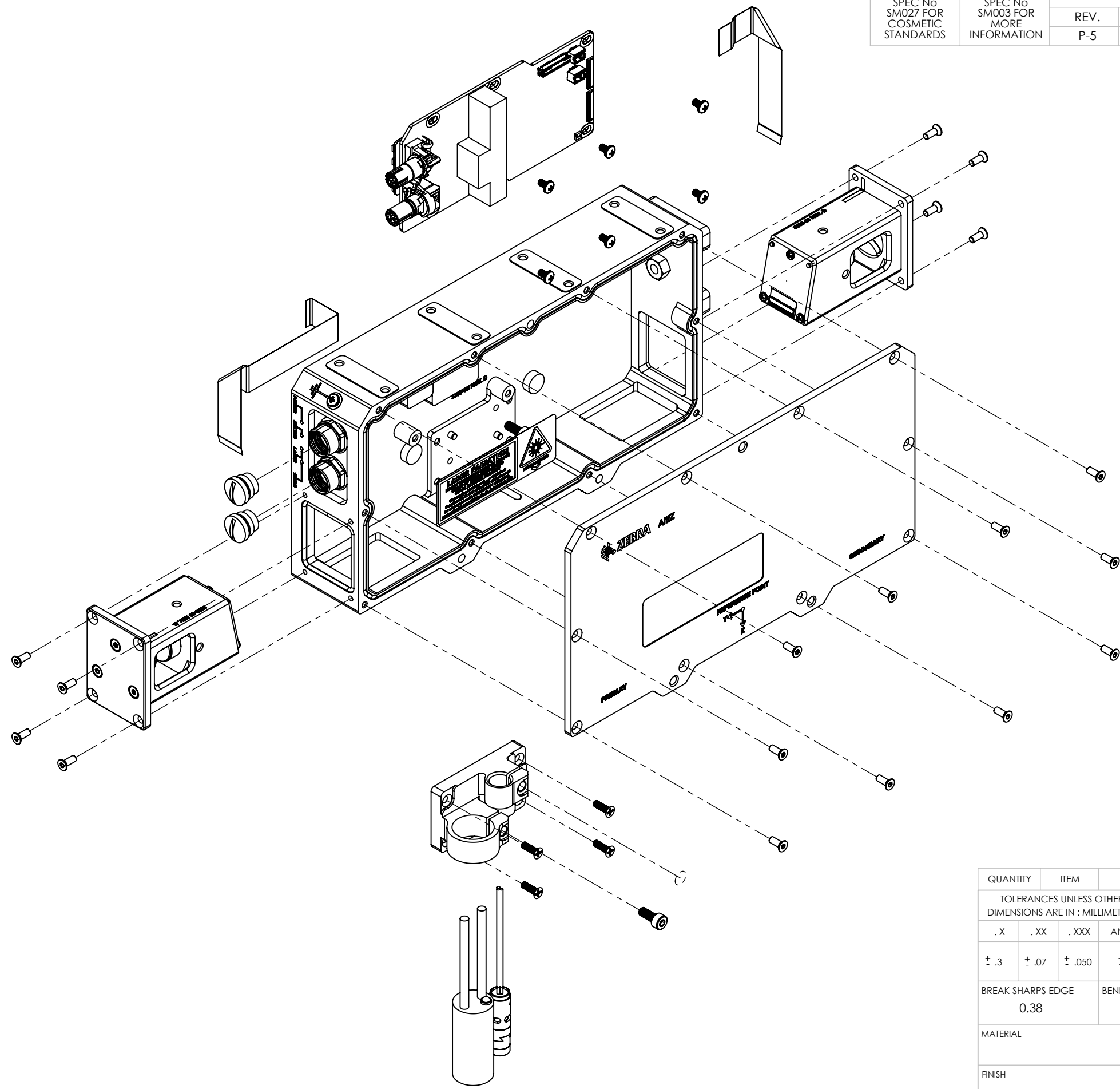

QUANTITY	ITEM	DESCRIPTION	MANUFACTURERS / PART No	NOTES
TOLERANCES UNLESS OTHERWISE SPECIFIED DIMENSIONS ARE IN : MILLIMETERS <input checked="" type="checkbox"/> INCHES <input type="checkbox"/>		GROUP IMAGING	THIRD ANGLE PROJECTION	
.X	.XX	.XXX	PROJECT 3D Profiler	1055 ST-REGIS DORVAL, QUEBEC H9P-2T4 THE INFORMATION CONTAINED IN THIS DRAWING IS THE SOLE PROPERTY OF MATROX. ANY REPRODUCTION IN PART OR AS A WHOLE WITHOUT THE WRITTEN PERMISSION OF MATROX IS PROHIBITED.
±.3	±.07	±.050	FILENAME TLA_5.SLRDRW	
BREAK SHARPS EDGE 0.38		BENDS 0.79R	DRAWN BY A. BERGERON	TITLE Zebra Altiz (Top Level Assy.) 0000-00
MATERIAL		CHECKED BY G. BLAIS	DATE August, 2023	
FINISH		SIZE B	SCALE 1:2	DRAWING NO. 0000-05-00 REV P-5 SHEET 3 OF 4

8 7 6 5 4 3 2 1

8 7 6 5 4 3 2 1

REVISIONS					
REV.	DESCRIPTION	D.O.	CHECKED BY	APPROVED	DATE
P-5	PRELIMINARY	AB	G. BLAIS		08/01/2023

SEE MATROX SPEC No SM027 FOR COSMETIC STANDARDS

SEE MATROX SPEC No SM003 FOR MORE INFORMATION

D
C
B
A

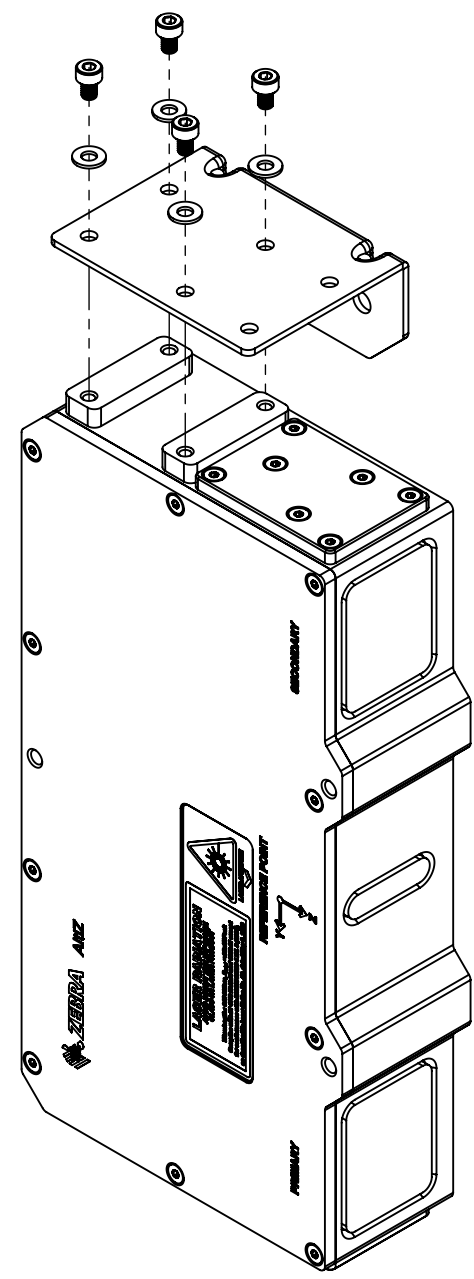
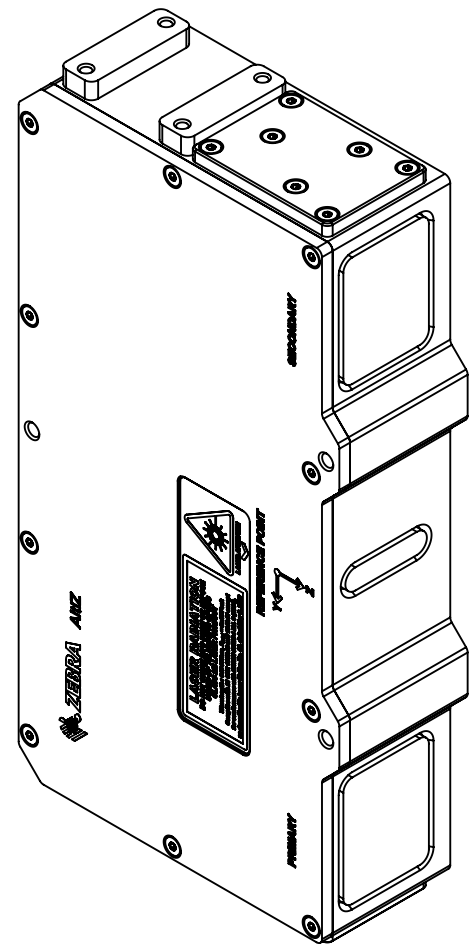
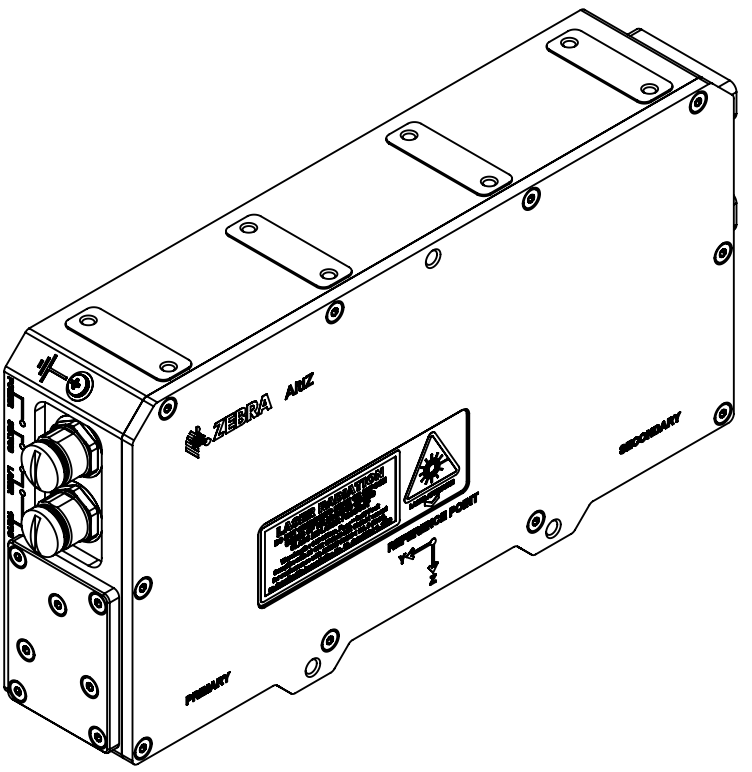

D
C
B
A

A

A

8 7 6 5 4 3 2 1

QUANTITY	ITEM	DESCRIPTION	MANUFACTURERS / PART No	NOTES
TOLERANCES UNLESS OTHERWISE SPECIFIED		GROUP	THIRD ANGLE PROJECTION	
DIMENSIONS ARE IN : MILLIMETERS 'X' INCHES <input type="checkbox"/>		IMAGING		
.X	.XX	.XXX	ANGLES	HOLES DIA.
±.3	±.07	±.050	± 0.5°	± .18 ± .00
BREAK SHARPS EDGE		BENDS		
0.38		0.79R		
MATERIAL		DRAWN BY		<p>matrox 1055 ST-REGIS DORVAL, QUEBEC H9P-2T4</p> <p>THE INFORMATION CONTAINED IN THIS DRAWING IS THE SOLE PROPERTY OF MATROX. ANY REPRODUCTION IN PART OR AS A WHOLE WITHOUT THE WRITTEN PERMISSION OF MATROX IS PROHIBITED.</p> <p>TITLE Zebra Altiz (Top Level Assy.) 0000-00</p>
FINISH		CHECKED BY		
		G. BLAIS		
		A. BERGERON		
		FILENAME		DRAWING NO.
		TLA_5.SLRDRW		
		DATE		REV
		August, 2023		P-5
		SCALE		SHEET
		1:2		4 OF 4